

Ordinance No. 22-055

An ordinance amending the "Construction" Chapter of the Code of the City of Arlington, Texas, 1987, through the amendment of Article I, Building Code, Sections 1.01 through 1.05, relative to adopting the 2021 Editions of the International Building Code, International Existing Building Code, International Residential Code, the International Energy Conservation Code, and the International Swimming Pool and Spa Code; adopting local amendments and associated appendices; through the amendment of Article IV, Registration, Permits and Inspections, in its entirety to reflect current practices and standards; through the amendment of Article V, Required Fees, in its entirety and reserving same for future codification; and through the amendment of Article VII, Signs, Section 7.10, Temporary Signs Near Polling Places, Subsection (A), relative to compliance with the Elections Chapter; providing for a fine of up to \$2,000 for each violation; providing this ordinance be cumulative; and providing for severability, governmental immunity, injunctions, publication, and an effective date

WHEREAS, after receipt of public comment in accordance with Section 214.217 of the Texas Local Government Code, and upon the advice and recommendation of the Building Code Board of Appeals, the City Council finds that it is in the public interest to adopt updated building codes for the preservation of public safety and the general welfare of its citizens; NOW THEREFORE

BE IT ORDAINED BY THE CITY COUNCIL OF THE CITY OF ARLINGTON, TEXAS:

1.

That the "Construction" Chapter of the Code of the City of Arlington, Texas, 1987, as amended, Article I, Building Code, Sections 1.01 through 1.05, are hereby repealed and replaced in their entirety and shall hereafter read as follows:

ARTICLE I

BUILDING CODE

Section 1.01 Title

This Chapter shall be known as the "Construction Chapter" of the Arlington City Code. It shall also be referenced as the "Building Code" of the City of Arlington. The

adoption of five (5) building-related codes published by the International Code Council, Inc., and local amendments thereto, are found within this Article. For additional adopted codes, see the following Chapters of the Arlington City Code:

International Fire Code, see "Fire Prevention" Chapter

International Fuel Gas Code, see "Mechanical" and "Plumbing" Chapters

International Mechanical Code, see "Mechanical" Chapter

International Plumbing Code, see "Plumbing" Chapter

National Electrical Code, see "Electrical" Chapter

Section 1.02 Adoption of Code

The International Building Code, 2021 Edition (hereinafter called "I.B.C. "); the International Existing Building Code, 2021 Edition (hereinafter called "I.E.B.C."); the International Residential Code, 2021 Edition (hereinafter called "I.R.C."); and the International Energy Conservation Code, 2021 Edition (hereinafter called "I.E.C.C. "); and the International Swimming Pool and Spa Code, 2021 Edition (hereinafter called "I.S.P.S.C."), as published by the International Code Council, Inc. are hereby adopted and designated, together with the deletions, amendments and addenda hereinafter contained, as the Building Code of the City of Arlington, the same as though said I.B.C., I.E.B.C., I.R.C., I.E.C.C. and I.S.P.S.C. were copied at length herein. Copies of the I.B.C., I.E.B.C., I.R.C., I.E.C.C. and I.S.P.S.C. and its Appendices shall be kept on file in the Office of the Building Official.

The adoption of the 2021 I.R.C. as stated herein, except that Section R313 of the 2003 I.R.C., as amended and originally adopted on August 23, 2005, by Ordinance No. 05-068, to read as follows is maintained:

R313.1 Fire sprinkler system. All R3 and U occupancies are required to have an approved fire sprinkler system.

Exception: Buildings with an approved fire department access.

Section 1.03 Code Defined; Rule of Construction

This Building Code shall include all of the provisions of the I.B.C., I.E.B.C., I.R.C., I.E.C.C., and I.S.P.S.C. as adopted by Section 1.02 above and all other provisions contained herein. In the event a conflict is determined to exist between said I.B.C., I.E.B.C., I.R.C., I.E.C.C., and I.S.P.S.C. as adopted and the other provisions of this Chapter, the provisions of this Chapter control. Items regulated by permit located on residential lots that are not specifically referenced in the I.R.C. are regulated by the I.B.C. or I.E.B.C.

Section 1.04 Amendments, Additions and Deletions

The adoption of the I.B.C, I.E.B.C., I.R.C., I.E.C.C., and I.S.P.S.C. as provided in Section 1.02 above, is modified and amended by the following:

- A. The addition thereto of Articles II, et seq., of this Chapter.
- B. The above-referenced codes are subject to the local amendments adopted herein and found at the following subsections:

International Building Code, see Subsection C

International Residential Code, see Subsection D

International Energy Conservation Code, see Subsection E

International Existing Building Code, see Subsection F

International Swimming Pool and Spa Code, see Subsection G

- C. The following local amendments to the International Building Code (I.B.C.) are hereby adopted:

- 1. The amendment of Section 101.1, entitled **Title.**, to read as follows:

Section 101.1 Title.

These regulations shall be known as the Building Codes of the City of Arlington, Texas, hereinafter referred to as "this code."

- 2. The amendment of the exceptions to Section 101.2, entitled **Scope.**, to read as follows:

Exceptions:

- 1. Detached one- and two-family dwellings and multiple single-family dwellings (townhouses) not more than three stories above grade plane in height with a separate means of egress and their accessory structures shall comply with the International Residential Code.
- 2. Portable and/or temporary storage buildings not exceeding three hundred twenty (320) square feet in area shall not be subject to the provisions of this Building Code for foundations and framing provided:
 - (a) The building shall not be intended or used for human occupancy;

- (b) No plumbing and/or mechanical improvements shall be permitted, and any electrical improvements are supervised by permits and work shall be installed in full compliance with the appropriate Chapter of the Code of the City of Arlington for such work; and
 - (c) A permit for such building shall have been obtained from the Building Official.
3. The amendment of Section 101.4, entitled **Referenced codes.**, to read as follows:

101.4 Referenced codes.

The other codes listed in Sections 101.4.1 through 101.4.8, and referenced elsewhere in this code, when specifically adopted, shall be considered part of the requirements of this code to the prescribed extent of each such reference. Whenever amendments have been adopted to the referenced codes and standards, each reference to said code and standard shall be considered to reference the amendments as well. Any reference to NFPA 70 or the Electrical Code shall mean the Electrical Code as adopted.

4. The amendment of Section 101.4.8, entitled **Electrical**, to read as follows:

101.4.8 Electrical.

The provisions of the Electrical Code shall apply to the installation of electrical systems, including alterations, repairs, replacement, equipment, appliances, fixtures, fittings and appurtenances thereto.

5. The amendment of Section 103 and 103.1, to read as follows:

**SECTION 103
DIVISION OF BUILDING INSPECTIONS**

103.1 Creation of enforcement agency.

The Division of Building Inspections is hereby created and the official in charge thereof shall be known as the Building Official.

6. The amendment of Section 104.6, entitled **Right of entry.**, to read as follows:

104.6 Right of entry

Where it is necessary to make an inspection to enforce any of the provisions of this Building Code, or whenever the Building Official or an authorized representative has reasonable cause to believe that there exists in any building or upon any premises any condition or violation which makes such building or premises unsafe, dangerous or hazardous, the Building Official or an authorized representative may enter such building or premises at all

reasonable times to inspect the same or to perform any duty imposed upon said Building Official by this Building Code. If such building or premises is occupied, the Building Official or an authorized representative shall first present proper credentials and request entry. If such building or premises is unoccupied, the Building Official shall first make a reasonable effort to locate the owner or other person having charge or control of the building or premises and request entry. If such entry is refused, or, if no owner or other person having charge or control of the building or premises can be located, the Building Official or an authorized representative shall have recourse to every remedy provided by law to secure entry.

7. The deletion of Section 104.10.1, entitled **Flood hazard areas**, in its entirety.
8. The addition of Section 104.12, entitled **Occupancy violations.**, which shall read as follows:

104.12 Occupancy violations.

Whenever any building, structure, or equipment therein which is regulated by this Building Code is being used contrary to the provisions of said Code, the Building Official or an authorized representative may order that such use be discontinued and/or that the building or structure, or a portion thereof, be vacated by written notice served on any person who is causing such use to be continued. Further, the Building Official or an authorized representative may order the evacuation of any building or premises, or a portion thereof, which constitutes a dangerous building as defined in Article XVI of this Chapter.

Notice to stop use shall be given by personal delivery or by certified mail, return receipt requested, to the person responsible for the continued use. Such person shall discontinue the use within the time prescribed by the Building Official after receipt of such notice and shall not resume the use of the building or premises until first rendering the same in compliance with this Building Code. Notice to vacate a dangerous building or premises shall be posted at or upon each exit of the said structure affected thereby, and shall be in substantially the following form:

"DO NOT ENTER
UNSAFE TO OCCUPY

It is a misdemeanor to occupy this building,
or to remove or deface this notice.

Arlington Building Official

(by) _____
(date) _____
(compliance due date) _____"

No person shall remain in or enter any building or premises which has been so posted, except that entry may be made to repair, demolish or remove the unsafe condition. Such entry or the destruction, defacing or removal of said notice prior to approval by the Building Official or an authorized representative shall be a violation of this Building Code.

9. The amendment of Section 105, entitled **PERMITS**, by deleting in its entirety.
10. The amendment of Section 107, entitled **CONSTRUCTION DOCUMENTS**, by deleting in its entirety.
11. The amendment of Section 109, entitled **FEES**, by adding Section 109.7, entitled **Re-inspection fee**, which shall read as follows:

109.7 Re-inspection fee.

A fee as established by city council resolution may be charged when:

1. The inspection called for is not ready when the inspector arrives;
2. No building address or permit card is clearly posted;
3. City approved plans are not on the job site available to the inspector;
4. The building is locked or work otherwise not available for inspection when called;
5. The job site is red-tagged twice for the same item;
6. The original red tag has been removed from the job site; or
7. Failure to maintain erosion control, trash control or tree protection.

Any re-inspection fees assessed shall be paid before any more inspections are made on that job site.

12. The amendment of Section 109, entitled **FEES**, by adding Section 109.8, entitled **Work without a permit**, and subsections 109.8.1 and 109.8.2, which shall read as follows:

109.8 Work without a permit.

109.8.1 Investigation.

Whenever work for which a permit is required by this code has been commenced without first obtaining a permit, a special investigation shall be made before a permit may be issued for such work.

109.8.2 Work without a permit Fee.

A work without a permit fee, in addition to the permit fee, shall be collected whether or not a permit is subsequently issued. The work without a permit fee shall be equal to the amount of the permit fee required by this code or the city fee schedule as applicable. The payment of such work without a permit fee shall not exempt the applicant from compliance with all other provisions of either this code or the technical codes nor from penalty prescribed by law.

13. The amendment of Section 110, entitled **INSPECTIONS**, by deleting in its entirety.
14. The amendment of Section 111, entitled **CERTIFICATE OF OCCUPANCY**, by deleting in its entirety.
15. The amendment of Section 113, entitled **MEANS OF APPEALS**, by deleting in its entirety.
16. The amendment of Section 114, entitled **VIOLATIONS**, by deleting in its entirety.
17. The amendment of Section 115, entitled **STOP WORK ORDER**, to read as follows:

**SECTION 115
STOP WORK ORDER**

115.1 Stop Work Order.

Whenever any work is being done contrary to the provisions of this Code, the Building Official may order the work stopped by notice in writing served on any persons engaged in the doing or causing such work to be done. Any such person shall forthwith stop such work until:

- a. He or she is authorized by the Building Official to proceed with the work; or
 - b. An appeal perfected pursuant to Section 2.06 of Article II has resulted in a waiver of the condition causing the stop order, or a finding that there is no cause for a stop order. Failure to stop such work, in addition to penalties and remedies elsewhere set forth, shall void any appeal.
18. The amendment of Section 116, entitled **UNSAFE STRUCTURES AND EQUIPMENT**, by deleting in its entirety.
 19. The amendment of Section 202, entitled **DEFINITIONS**, by amending the definitions of **AMBULATORY CARE FACILITY, ASSISTED**

LIVING FACILITY, REPAIR GARAGE, and SPECIAL INSPECTOR to read as follows:

AMBULATORY CARE FACILITY. Buildings or portions thereof used to provide medical, surgical, psychiatric, nursing or similar care on a less than 24-hour basis to persons who are rendered incapable of self-preservation by the services provided or staff has accepted responsibility for care recipients already incapable. This group may include but is not to be limited to the following:

- Dialysis centers
- Sedation dentistry
- Surgery centers
- Colonic centers
- Psychiatric centers

ASSISTED LIVING FACILITIES. A building or part thereof housing persons, on a 24-hour basis, who because of age, mental disability or other reasons, live in a supervised residential environment which provides personal care services. The occupants are capable of responding to an emergency situation without physical assistance from staff.

REPAIR GARAGE. A building, structure or portion thereof used for servicing or repairing motor vehicles. This occupancy shall also include garages involved in minor repair, modification and servicing of motor vehicles for items such as lube changes, inspections, windshield repair or replacement, shocks, minor part replacement and other such minor repairs.

SPECIAL INSPECTOR. A qualified person employed or retained by an approved agency who shall prove to the satisfaction of the registered design professional in responsible charge and approved by the Building Official as having the competence necessary to inspect a particular type of construction requiring special inspection.

20. The amendment of Section 303.1.3, entitled **Associated with Group E occupancies**, to read as follows:

303.1.3 Associated with Group E occupancies.

A room or space used for assembly purposes that is associated with a Group E occupancy is not considered a separate occupancy, except when applying the assembly requirements of Chapter 10 and 11.

21. The amendment of Section 304.1, entitled **Business Group B.**, by adding the following two items to the list of occupancies listed therein:

Fire stations
Police stations with detention facilities for 5 or less

22. The amendment of Section 307.1.1, entitled **Uses other than Group H**, by amending Exception 4 to read as follows:

4. Cleaning establishments that utilize combustible liquid solvents having a flash point of 140°F (60°C) or higher in closed systems employing equipment listed by an approved testing agency, provided that this occupancy is separated from all other areas of the building by 1-hour fire barriers constructed in accordance with Section 707, or 1-hour horizontal assemblies constructed in accordance with Section 711, or both. See also Chapter 21, Dry Cleaning Plant provision of the Fire Code.

23. The amendment of Section 403.1, entitled **Applicability**, to amend Exception 3 to read as follows:

3. The open air portion of a building containing a Group A-5 occupancy in accordance with Section 303.6.

24. The amendment of Section 403.3, entitled **Automatic Sprinkler System**, by deleting the Exception.

25. The amendment of Section 403.3.2, entitled **Water supply to required fire pumps**, to read as follows:

403.3.2 Water supply to required fire pumps.

In buildings that are more than 120 feet (36.5 m) in building height, required fire pumps shall be supplied by connections to no fewer than two water mains located in different streets. Separate supply piping shall be provided between each connection to the water main and the pumps. Each connection and the supply piping between the connection and the pumps shall be sized to supply the flow and pressure required for the pumps to operate.

Exception: Two connections to the same main shall be permitted provided that the main is valved such that an interruption can be isolated so that the water supply will continue without interruption through no fewer than one of the connections.

26. The amendment of Section 404.10, entitled **Exit stairways in an atrium**, to read as follows:

Section 404.10 Exit Stairways in an atrium.

Where an atrium contains an interior exit *access* stairway all the following shall be met:

1. The entry of the exit stairway is the edge of the closest riser of the exit stairway.

2. The entry of the exit stairway shall have access from a minimum of two directions.
 3. The distance between the entry to an exit stairway in an atrium and the entrance to a minimum of one exit stairway enclosed in accordance with Section 1023.2 shall comply with the separation required by Section 1007.1.1.
 4. Exit access travel distance shall be measured to the closest riser of the exit stairway.
 5. Not more than 50 percent of the exit stairways shall be located in the same atrium.
27. The amendment of Section 406.3.3.1, entitled **Carport separation**, to read as follows:

406.3.3.1 Carport Separation

A separation is not required between a Group R-3 and U carport, provided that the carport is entirely open on two or more sides and there are not enclosed areas above. A fire separation is not required between a Group R-2 and U carport, provided that the carport is entirely open on all sides and that the distance between the two is at least 10 feet (3048 mm).

28. The amendment of Section 423.5.1, entitled **Required occupant capacity**, to read as follows:

423.5.1 Required occupant capacity.

The required occupant capacity of the storm shelter shall include all of the buildings on the site and shall be the greater of the following:

1. The total occupant load of the classrooms, vocational rooms and offices in the Group E occupancy.
2. The occupant load of the largest indoor assembly space that is associated with the Group E occupancy.

Exceptions:

1. Where a new building is being added on an existing Group E site, and where the new building is not of sufficient size to accommodate the required occupant capacity of the storm shelter for all of the buildings on the site, the storm shelter shall at a minimum accommodate the required occupant capacity for the new building.

2. Where approved by the building official, the required occupant capacity of the shelter shall be permitted to be reduced by the occupant capacity of any existing storm shelters on the site.
 3. Where approved by the building official, the actual number of occupants for whom each occupied space, floor or building is designed, although less than those determined by occupant load calculation, shall be permitted to be used in the determination of the required design occupant capacity for the storm shelter.
29. The amendment of Section 503.1., entitled **General**, to read as follows:

503.1. General.

Unless otherwise specifically modified in Chapter 4 and this chapter, building height, number of stories and building area shall not exceed the limits specified in Section 504 and 506 based on the type of construction as determined by Section 602 and the occupancies as determined by Section 302 except as modified hereinafter. Building height, number of stores and building area provisions shall be applied independently. For the purposes of determining area limitations, height limitations and type of construction, each portion of a building separated by one or more fire walls complying with Section 706 shall be considered to be a separate building.

Where a building contains more than one distinct type of construction, the building shall comply with the most restrictive area, height, and stories, for the lesser type of construction or be separated by fire walls, except as allowed in Section 510.

30. The amendment of Section 506.2, entitled **Allowable area determination**, by amending Table 506.2, entitled **ALLOWABLE AREA FACTOR IN SQUARE FEET** by deleting footnote "i" in its entirety.
31. The amendment of Section 506.3.1, entitled **Minimum percentage of perimeter**, to read as follows:

506.3.1 Minimum percentage of perimeter.

To qualify for an area factor increase based on frontage, a building shall have not less than 25 percent of its perimeter on a public way or open space. Such open space shall be either on the same lot or dedicated for public use and shall be accessed from a street or approved fire lane.

In order to be considered as accessible, if not in direct contact with a street or fire lane, a minimum 10-foot-wide pathway meeting fire department access from the street or approved fire lane shall be provided.

32. The amendment of Section 708.4.2, entitled **Fireblocks and draftstops in combustible construction.**, to read as follows:

708.4.2 Fireblocks and draftstops in combustible construction.

In combustible construction where fire partitions do not extend to the underside of the floor or roof sheathing, deck or slab above, the space above and along the line of the fire partition shall be provided with one of the following:

1. Fireblocking up to the underside of the floor or roof sheathing, deck or slab above using materials complying with Section 718.2.1.
2. Draftstopping up to the underside of the floor or roof sheathing, deck or slab above using materials complying with Section 718.3.1 for floors or Section 718.4.1 for attics.

Exceptions:

1. Buildings equipped with an automatic sprinkler system installed throughout in accordance with Section 903.3.1.1, or in accordance with Section 903.3.1.2 provided that sprinkler protection is provided in the space between the top of the fire partition and the underside of the floor or roof sheathing, deck or slab above as required for systems complying with Section 903.3.1.1. Portions of buildings containing concealed spaces filled with noncombustible insulation as permitted for sprinkler omission shall not apply to this exception for draftstopping.
2. Where corridor walls provide a sleeping unit separation, draftstopping shall only be required above one of the corridor walls.
3. In Group R-2 occupancies with fewer than four dwelling units, fireblocking and draftstopping shall not be required.
4. In Group R-2 occupancies up to and including four stories in height in buildings not exceeding 60 feet (18 288 mm) in height above grade plane, the attic space shall be subdivided by draftstops into areas not exceeding 3,000 square feet (279 m²) or above every two dwelling units, whichever is smaller.
5. In Group R-3 occupancies with fewer than three dwelling units, fireblocking and draftstopping shall not be required in floor assemblies.

33. The amendment of Section 718.3, entitled **Draftstopping in floors**, by amending the Exception to read as follows:

Exception: Buildings equipped throughout with an automatic sprinkler system in accordance with Section 903.3.1.1. and provided that in combustible construction, sprinkler protection is provided in the floor space.

34. The amendment of Section 718.4, entitled **Draftstopping in attics**, by amending the Exception to read as follows:

Exception: Buildings equipped throughout with an automatic sprinkler system in accordance with Section 903.3.1.1 and provided that in combustible construction, sprinkler protection is provided in the attic space.

35. The amendment of Section 901.6.1, entitled **Automatic sprinkler systems**, by adding Section 901.6.1.1, entitled **Standpipe testing**, which shall read as follows:

901.6.1.1 Standpipe Testing.

Building owners/managers must maintain and test standpipe systems as per NFPA 25 requirements. The following additional requirements shall be applied to the testing that is required every 5 years:

1. The piping between the Fire Department Connection (FDC) and the standpipe shall be backflushed when foreign material is present, and also hydrostatically tested for all FDC's on any type of standpipe system. Hydrostatic testing shall also be conducted in accordance with NFPA 25 requirements for the different types of standpipe systems.
2. For any manual (dry or wet) standpipe system not having an automatic water supply capable of flowing water through the standpipe, the tester shall connect hose from a fire hydrant or portable pumping system (as approved by the fire code official) to each FDC, and flow water through the standpipe system to the roof outlet to verify that each inlet connection functions properly. Confirm that there are no open hose valves prior to introducing water into a dry standpipe. There is no required pressure criteria at the outlet. Verify that check valves function properly and that there are no closed control valves on the system.

3. Any pressure relief, reducing, or control valves shall be tested in accordance with the requirements of NFPA 25. All hose valves shall be exercised.
 4. If the FDC is not already provided with approved caps, the contractor shall install such caps for all FDC's as required by the fire code official.
 5. Upon successful completion of standpipe test, place a blue tag (as per Texas Administrative Code, Fire Sprinkler Rules for Inspection, Test and Maintenance Service (ITM) Tag) at the bottom of each standpipe riser in the building. The tag shall be check-marked as "Fifth Year" for Type of ITM, and the note on the back of the tag shall read "5 Year Standpipe Test" at a minimum.
 6. The procedures required by Texas Administrative Code Fire Sprinkler Rules with regard to Yellow Tags and Red Tags or any deficiencies noted during the testing, including the required notification of the local Authority Having Jurisdiction (fire code official) shall be followed.
 7. Additionally, records of the testing shall be maintained by the owner and contractor, if applicable, as required by the State Rules mentioned above and NFPA 25.
 8. Standpipe system tests where water will be flowed external to the building shall not be conducted during freezing conditions or during the day prior to expected night time freezing conditions.
 9. Contact the fire code official for requests to remove existing fire hose from Class II and III standpipe systems where employees are not trained in the utilization of this firefighting equipment. All standpipe hose valves must remain in place and be provided with an approved cap and chain when approval is given to remove hose by the fire code official.
36. The amendment of Section 902.1, entitled **Pump and riser room size**, to be retitled **Pump and riser room size and location**, and shall read as follows:

902.1 Pump and riser room size and location.

All pump and riser rooms shall be provided on the ground floor or other approved level of fire department apparatus access and with a door directly accessible from the exterior of the building in an approved location. The door must be labeled as the "RISER ROOM" by an approved method.

All sprinkler riser rooms shall provide adequate work-around room between fire protection equipment and any interior/exterior walls, obstructions, or other equipment. The minimum spacing around all fire protection equipment, piping, valves, etc. shall be no less than 36 inches from all functional sides. Fire pump and riser rooms shall be provided with a door[doors] and an unobstructed entry/exit passageway large enough to allow removal of the largest piece of equipment. A key box complying with Section 506.1 shall be installed at the fire sprinkler riser and/or pump room. Additional safeguards shall be provided as determined by the Fire Code Official.

37. The amendment of Section 903.1.1, entitled **Alternative protection**, to read as follows:

903.1.1 Alternative protection.

Alternative automatic fire-extinguishing systems complying with Section 904 shall be permitted in addition to automatic sprinkler protection, where recognized by the applicable standard and approved by the fire code official.

38. The amendment of Section 903.2, entitled **Where required**, by adding additional language and deleting the Exception, so that the section shall read as follows:

Section 903.2 Where required

Approved automatic sprinkler systems in new buildings and structures shall be provided in the locations described in Sections 903.2.1 through 903.2.12.

Automatic Sprinklers shall not be installed in elevator machine rooms, elevator machine spaces, and elevator hoistways, other than pits where such sprinklers would not necessitate shunt trip requirements under any circumstances. Storage shall not be allowed within the elevator machine room. Signage shall be provided at the entry doors to the elevator machine room indicating "ELEVATOR MACHINERY – NO STORAGE ALLOWED. "

39. The addition of Section 903.2.1.8, entitled **Special amusement building**, to read as follows:

903.2.1.8 Special amusement building.

Special amusement buildings shall be equipped throughout with an automatic sprinkler system.

Exception: An automatic sprinkler system need not be provided when an amusement building shall be in existence less than 30 continuous days and when the construction and use is approved by the Fire Code Official.

40. The amendment of Section 903.2.4, entitled **Group F-1**, to read as follows:

903.2.4 Group F-1.

An automatic sprinkler system shall be provided throughout all buildings where the fire area containing a Group F-1 occupancy exceeds 12,000 square feet (1115 m²), or where more than two stories in height, or where the combined fire area on all floors, including mezzanines, exceeds 24,000 square feet (2230 m²).

41. The amendment of Section 903.2.4.2, entitled **Group F-1 distilled spirits**, to read as follows:

903.2.4.2 Group F-1 distilled spirits.

An automatic sprinkler system shall be provided throughout a Group F-1 fire area used for the manufacture of distilled spirits involving more than 120 gallons of distilled spirits (>16% alcohol) in the fire area at any one time.

42. The amendment of Section 903.2.8, entitled **Group R**, to read as follows:

903.2.8 Group R.

An automatic sprinkler system shall be installed throughout all buildings with a Group R fire area. One- and two-family dwellings, Group R-3; Group R-4 Condition 1; and townhouses not exceeding two stories in height shall be permitted to comply with Section 903.3.1.3. Buildings up to and including four stories in height, not exceeding 60 feet in height above the lowest level of fire apparatus access, shall be permitted to comply with Section 903.3.1.2. All other buildings with a Group R fire area shall comply with Section 903.3.1.1.

43. The amendment of Section 903.2.8.3, entitled **Group R-4 Condition 2**, to read as follows:

903.2.8.3 Group R-4 Condition 2.

An automatic sprinkler system installed in accordance with Section 903.3.1.2 shall be permitted in Group R-4 Condition 2 occupancies.

44. The amendment of Section 903.2.9.3, entitled **Group S-1 distilled spirits or wine**, to read as follows:

903.2.9.3 Group S-1 distilled spirits or wine.

An automatic sprinkler system shall be provided throughout a Group S-1 fire area used for the bulk storage of distilled spirits or wine involving more than 120 gallons of distilled spirits or wine (>16% alcohol) in the fire area at any one time.

45. The amendment of Section 903.2.9.4, entitled **Group S-1 upholstered furniture and mattresses**, by deleting the Exception in its entirety.
46. The amendment of Section 903.2.9, entitled **Group S-1**, by adding Section 903.2.9.5, entitled **Self-service storage facility**, which shall read as follows:

903.2.9.5 Self-Service Storage Facility.

An automatic sprinkler system shall be installed throughout all self-service storage facilities.

Exception: One-story self-service storage facilities that have no interior corridors, with at least a one-hour fire barrier separation wall installed between every storage compartment.

47. The amendment of Section 903.2.11.3, entitled **Buildings 55 feet or more in height**, by deleting the Exception and amending the section to read as follows:

903.2.11.3 Buildings 55 feet or more in height.

An automatic sprinkler system shall be installed throughout buildings that have one or more stories other than penthouses in compliance with Section 1510 of the International Building Code, located 55 feet (16 764 mm) or more above the lowest level of fire department vehicle access, measured to the finished floor.

48. The amendment of Section 903.2.11, entitled **Specific building areas and hazards**, by adding Section 903.2.11.7 and Section 903.2.11.8, which shall read as follows:

903.2.11.7 High-Piled Combustible Storage.

For any building with a clear height exceeding 12 feet (4572 mm), see Chapter 32 of the International Fire Code to determine if those provisions apply.

903.2.11.8 Spray Booths and Rooms.

New and existing spray booths and spraying rooms shall be protected by an approved automatic fire-extinguishing system.

49. The amendment of Section 903.3.1.1, entitled **NFPA 13 sprinkler systems**, to read as follows:

903.3.1.1 NFPA 13 sprinkler systems.

Where the provisions of this code require that a building or portion thereof be equipped throughout with an automatic sprinkler system in accordance with this section, sprinklers shall be installed throughout in accordance with NFPA 13, with the exclusion of Section 8.15.8 of that standard, and except as provided in Sections 903.3.1.1.1 and 903.3.1.1.2.

50. The amendment of Section 903.3.1.1.1, entitled **Exempt locations**, to read as follows:

903.3.1.1.1 Exempt locations.

Where approved by the Fire Code Official, sprinklers shall not be required in the following rooms or areas where such rooms or areas are protected with an approved automatic fire alarm system in accordance with Section 907.2. Sprinklers shall not be omitted from any room or area merely because of the following circumstances: the potential water damage from sprinkler activation; the fire-resistance-rated construction of the room or area; or that a room or area contains electrical equipment.

1. Any room where the application of water constitutes a serious life or fire hazard.
2. Any room or area where sprinklers are considered undesirable because of the nature of the contents within that room or area.
3. Generator or transformer rooms, under the direct control of a public utility, separated from the remainder of the building by walls and floor/ceiling or roof/ceiling assemblies having a fire-resistance-rating of not less than two hours.
4. Machine rooms, elevator machinery spaces, control rooms, control spaces, and elevator hoist ways.

Buildings and portions thereof shall be considered to be covered by an automatic sprinkler system throughout and in compliance with this code if they contain areas that are not required to have sprinkler

coverage by this code, or any other locations as approved by the Fire Code Official.

51. The amendment of Section 903.3.1.2, entitled **NFPA 13R sprinkler systems**, to read as follows:

903.3.1.2 NFPA 13R sprinkler systems.

Automatic sprinkler systems in Group R occupancies shall be permitted to be installed throughout in accordance with NFPA 13R where the Group R occupancy meets all of the following conditions:

1. Four stories or less above grade plane.
2. The floor level of the highest story is 35 feet (10668 mm) or less above the lowest level of fire department vehicle access.
3. The floor level of the lowest story is 35 feet (10668 mm) or less below the lowest level of fire department vehicle access.

The number of stories of Group R occupancies constructed in accordance with Section 510.2 and 510.4 shall be measured from grade plane.

52. The amendment of Section 903.3.1.2.1, entitled **Balconies and decks**, to read as follows:

903.3.1.2.1 Balconies and decks.

Dry or antifreeze sidewall sprinkler protection shall be provided for exterior balconies, decks, and ground floor patios of buildings protected by a system complying with Section 903.3.1.2, provided there is a roof or deck above.

Sidewall sprinklers that are used to protect such areas shall be permitted to be located such that their deflectors are within 1 inch to 6 inches below the structural members and a maximum distance of 14 inches below the deck above.

53. The amendment of Section 903.3.1.2.2, entitled **Corridors and balconies in the means of egress**, to read as follows:

903.3.1.2.2 Corridors and balconies in the means of egress.

Sprinkler protection shall be provided in all corridors and for all balconies.

54. The amendment of Section 903.3.1.2.3, entitled **Attics**, by deleting said section in its entirety and replacing with the following to read as follows:

Section 903.3.1.2.3 Attached Garages and Attics.

Sprinkler protection is required in attached garages, and in the following attic spaces:

1. Attics that are used or intended for living purposes or storage shall be protected by an automatic sprinkler system.
2. Where fuel-fired equipment is installed in an un-sprinklered attic, not fewer than one quick-response intermediate temperature sprinkler shall be installed above the equipment.
3. Attic spaces of buildings that are two or more stories in height above grade plane or above the lowest level of fire department vehicle access.
4. Group R-4, Condition 2 occupancy attics not required by Item 1 or 3 to have sprinklers shall comply with one of the following:
 - 4.1. Provide automatic sprinkler system protection.
 - 4.2. Provide a heat detection system throughout the attic that is arranged to activate the building fire alarm system.
 - 4.3. Construct the attic using noncombustible materials.
 - 4.4. Construct the attic using fire-retardant-treated wood complying with Section 2303.2 of the International Building Code.

4.5. Fill the attic with noncombustible insulation.

55. The amendment of Section 903.3.1.3, entitled **NFPA 13D sprinkler systems**, to read as follows:

903.3.1.3 NFPA 13D sprinkler systems.

Automatic sprinkler systems installed in one- and two-family dwellings; Group R-3; Group R-4, Condition 1; and townhouses shall be permitted to be installed throughout in accordance with NFPA 13D or in accordance with state law.

56. The amendment of Section 903.3.1, entitled **Standards**, by adding Section 903.3.1.4, entitled **Multipurpose sprinkler systems**, which shall read as follows:

903.3.1.4 Multipurpose sprinkler systems.

Can be used for one- and two-family dwellings where one structure is located on a dedicated lot. The structures must also have a minimum of 10' horizontal separation between roof line edges.

57. The amendment of Section 903.3.1, entitled **Standards**, by adding Section 903.3.1.5, entitled **Freeze protection**, et seq., which shall read as follows:

903.3.1.5 Freeze protection.

Freeze protection systems for automatic fire sprinkler systems shall be in accordance with the requirements of the applicable referenced NFPA standard and this section.

903.3.1.5.1 Attics.

Only dry pipe, preaction, or listed antifreeze automatic fire sprinkler systems shall be allowed to protect attic spaces.

Exception: Wet-pipe fire sprinkler systems shall be allowed to protect non-ventilated attic spaces where:

1. The attic sprinklers are supplied by a separate floor control valve assembly to allow ease of draining the attic system without impairing sprinklers throughout the rest of the building, and
2. Adequate heat shall be provided for freeze protection as per the applicable referenced NFPA standard, and

3. The attic space is a part of the building's thermal, or heat, envelope, such that insulation is provided at the roof deck, rather than at the ceiling level.

903.3.1.5.2 Heat trace/insulation.

Heat trace/insulation shall only be allowed where approved by the fire code official for small sections of large diameter water-filled pipe.

58. The amendment of Section 903.3.5, entitled **Water supplies**, by adding a second paragraph, which shall read as follows:

Water supply as required for such systems shall be provided in conformance with the supply requirements of the respective standards; however, every water-based fire protection system shall be designed with a 10-psi safety factor. Reference Section 507.4 for additional design requirements.

59. The amendment of Section 903.3.5, entitled **Water supplies**, by adding Section 903.3.5.3, entitled **Aboveground water supply vaults/housings**, which shall read as follows:

903.3.5.3 Aboveground water supply vaults/housings.

All new service mains for supplying water to fire protection systems that continue in aboveground vaults or housings shall be protected against freezing and impact damage. All new vaults or housings with aboveground water supplies, including backflow prevention assemblies, shall be provided with a reliable heat source or other method to protect the piping/assemblies from freezing. All new vaults shall be protected from vehicle impact by means in accordance with Section 312.

60. The amendment of Section 903.3.7, entitled **Fire department connections**, by adding Section 903.3.7.1, entitled **Additional connections**, which shall read as follows:

903.3.7.1 Additional connections.

If required fire flow requirements exceed the initial 1500 G.P.M. for any system, building, or portion thereof, an additional fire department connection complying with this section shall be provided for each additional 1500 G.P.M. or fraction thereof. If a single additional connection is required by this section and if provided in a manifold, the supply piping from the manifold to the sprinkler system shall be a minimum of 6 inches. If two additional connections are required by this section and if provided in a manifold, the supply piping from the manifold to the sprinkler system shall

be a minimum of 8 inches. For three or more additional connections, and for any arrangement of manifolded fire department connections, the supply piping to the system shall be capable of supplying the aggregate volume of incoming water.

61. The amendment of Section 903.4, entitled **Sprinkler system supervision and alarms**, by adding a second paragraph after the exceptions, which shall read as follows:

Sprinkler and standpipe system water-flow detectors shall be provided for each floor tap to the sprinkler system and shall cause an alarm upon detection of water flow for more than 45 seconds. All control valves in the sprinkler and standpipe systems except for fire department hose connection valves shall be electrically supervised to initiate a supervisory signal at the central station upon tampering.

62. The amendment of Section 903.4.2, entitled **Alarms**, to read as follows:

903.4.2 Alarms.

Each automatic sprinkler system shall have a single, approved device to be installed on the exterior of the building on the address side of the building, or in an alternative location as approved by the Fire Code Official; additional devices may be required at the discretion of the Fire Code Official. This device shall be a weatherproof horn/strobe notification appliance with a minimum 75 candela strode rating.

Installations intended to comply with this section shall have a single audible/visual notification appliance to be located in an approved, normally occupied location, within each occupancy group of a building. Incidental uses shall not require an additional notification device. Additional notification devices not mentioned in this section shall not be allowed.

63. The amendment of Section 903.4.2, entitled **Alarms**, by adding Section 903.4.2.1, entitled **Waterflow alarm initiation**, which shall read as follows:

903.4.2.1 Waterflow alarm initiation.

Any waterflow-type of detector device required by this code on all sprinkler or standpipe systems shall cause an alarm upon the detection of waterflow between 45 and 90 seconds. All alarms caused by the initiation of waterflow shall be programmed to be audible and shall continue to report as such until the flow of water has been disrupted.

64. The amendment of Section 903.4.3, entitled **Floor control valves**, to read as follows:

903.4.3 Floor control valves.

When a standpipe system is installed or required to be installed in a building, a separate indicating floor control valve shall be installed for each connection to an express main or supply feed to each floor throughout the building. A separate control valve shall be provided for each floor that is served by a standpipe system or protected by an automatic sprinkler system and shall be supervised by the building's fire alarm system. Each floor control valve shall also be accompanied by a waterflow switch which shall comply with Section 903.4.2.1.

65. The amendment of Section 903, entitled **AUTOMATIC SPRINKLER SYSTEMS**, by adding Section 903.6, entitled **Spray booths and rooms**, which shall read as follows:

903.6 Spray booths and rooms.

New and existing spray booths and spray rooms shall be protected by an approved automatic fire extinguishing system in accordance with Section 2404.4 of the International Fire Code.

66. The amendment of Section 904.4.2.1, entitled **Audible and visible signals**, to read as follows:

904.4.2.1 Audible and visible signals.

All systems installed in accordance with Section 904 that are not otherwise required to be interconnected to the building's fire alarm system shall be provided with a single approved audible (local) notification appliance or method to announce the activation of such system. The audibility of all required notification appliances shall be verified.

67. The amendment of Section 905.2, entitled **Installation standard**, to read as follows:

905.2 Installation standard.

Standpipe systems shall be installed in accordance with this section and NFPA 14. Manual dry standpipe systems shall be supervised with a minimum of 10 psig and a maximum of 40 psig air pressure with a high/low alarm and shall be designed with the following hydraulic factors: Static – 175psi, Residual – 174psi, Flow – 1500gpm. Fire department connections for standpipe systems shall be in accordance with Section 912.

68. The amendment of Section 905.3.2, entitled **Group A**, by deleting Exceptions #1 and #2.

69. The amendment of Section 905.3, entitled **Required installations**, by adding Section 905.3.9, entitled **Buildings exceeding 10,000 sq. ft.**, which shall read as follows:

905.3.9 Buildings Exceeding 10,000 sq. ft.

In buildings exceeding 10,000 square feet in area per story and where any portion of the building's interior area is more than 200 feet (60960 mm) of travel, vertically and horizontally, from the nearest point of fire department vehicle access, Class I automatic wet or manual wet standpipes shall be provided.

Exceptions:

1. Automatic dry, semi-automatic dry, and manual dry standpipes are allowed as provided for in NFPA 14 where approved by the fire code official.
2. R-2 occupancies of four stories or less in height having no interior corridors.

70. The amendment of Section 905.4, entitled **Location of Class I standpipe hose connections**, by amending Items 1, 3, and 5, and adding Item 7, all of which shall read as follows:

1. In every required exit stairway, a hose connection shall be provided for each story above and below grade plane. Hose connections shall be located at an intermediate landing between stories, unless otherwise approved by the fire code official.

Exception: A single hose connection shall be permitted to be installed in the open corridor or open breezeway between open stairs that are not greater than 75 feet (22 860 mm) apart.

3. In every exit passageway, at the entrance from the exit passageway to other areas of a building.

Exception: Where floor areas adjacent to an exit passageway are reachable from an exit stairway hose connection by a 30-foot (9144 mm) hose stream from a nozzle attached to 100 feet (30 480mm) of hose, a hose connection shall not be required at the entrance from the exit passageway to other areas of the building.

5. Where the roof has a slope less than 4 units vertical in 12 units horizontal (33.3-percent slope), each standpipe provided with a two-way a hose connection shall be located to serve the roof or at the highest landing of an exit stairway with stair access to the roof provided in accordance with Section 1011.12.

7. When required by this Chapter, standpipe connections shall be placed adjacent to all required exits to the structure and at 200 feet (60 960 mm) intervals along major corridors thereafter, or as otherwise approved by the fire code official.

71. The amendment of Section 905.8, entitled **Dry standpipes**, to read as follows:

905.8 Dry standpipes.

Dry standpipes shall not be installed.

Exception: Where subject to freezing and in accordance with NFPA 14. Additionally, manual dry standpipe systems shall be supervised with a minimum of 10 psig and a maximum of 40 psig air pressure with a high/low Supervisory alarm.

72. The amendment of Section 905.9, entitled **Valve supervision**, by adding a second paragraph after the exceptions, which shall read as follows:

Sprinkler and standpipe system water-flow detectors shall be provided for each floor tap to the sprinkler system and shall cause an alarm upon detection of water flow for more than 45 seconds. All control valves in the sprinkler and standpipe systems except for fire department hose connection valves shall be electrically supervised to initiate a supervisory signal at the central station upon tampering.

73. The amendment of Section 906.1, entitled **Where required**, Subsection 1, by deleting Exception 3, 3.1-3.5, in its entirety.

74. The amendment of Section 907.1.2, entitled **Fire alarm shop drawings**, by adding the following subsections, which shall read as follows:

907.1.2.1

The type, location, power supply detail, and interconnectivity of single- or multiple- station smoke alarms.

907.1.2.2

The type, location, power supply detail, and interconnectivity of single- or multiple- station carbon monoxide alarms.

75. The amendment of Section 907.1.3, entitled **Equipment**, by adding the following subsections, which shall read as follows:

907.1.3.1 Fire alarm control panel.

The fire alarm control panel shall be installed in an approved location adjacent to the main entrance to the building unless

otherwise approved by the Fire Code Official. In such instances, an annunciator shall be installed at the main entrance.

907.1.3.2 Key/Codes.

Fire alarm control panel functions such as "silence" and "reset" shall be operable without the use of a key or code. The panel cover may be locked, but a key to unlock it shall be located in a key box, in accordance with Section 506.

76. The amendment of Section 907.1, entitled **General.**, by adding Section 907.1.4, entitled **Design standards**, which shall read as follows:

907.1.4 Design standards.

Fire alarm systems, emergency voice alarm communication systems and their appurtenances shall be designed, installed and maintained in accordance with NFPA 72.

All newly installed systems, including those which are installed to replace existing systems and those that are installed to comply with Section 903.4 through 903.4.2, shall be of the addressable type. Fire alarm systems serving more than seventy-five (75) detector-type initiating devices or more than 200 total devices, shall be analog intelligent addressable fire detection systems.

Exception: Existing systems need not comply unless the total system alterations exceed 30% of the original system design or when the building has undergone more than 50% alteration initiated after October 1st, 1998. Timeframes to comply shall be determined by the Fire Code Official.

77. The amendment of Section 907.2.1, entitled **Group A**, to read as follows:

907.2.1 Group A.

A manual fire alarm system that activates the occupant notification system in accordance with Section 907.5 shall be installed in Group A occupancies having an occupant load of 300 or more persons, or where the occupant load is more than 100 persons above or below the lowest level of exit discharge. Group A occupancies not separated from one another in accordance with Section 707.3.10 of the International Building Code shall be considered as a single occupancy for the purposes of applying this section. Portions of Group E occupancies occupied for assembly purposes shall be provided with a fire alarm system as required for the Group E occupancy.

Exception: Manual fire alarm boxes are not required where the building is equipped throughout with an automatic sprinkler system installed in accordance with Section 903.3.1.1 and the occupant notification appliances will activate throughout the notification zones upon sprinkler water flow.

Activation of fire alarm notification appliances shall:

1. Cause illumination of the means of egress with light of not less than 1 foot-candle (11 lux) at the walking surface level, and
2. Stop any conflicting or confusing sounds and visual distractions.

78. The amendment of Section 907.2.3, entitled **Group E.**, to read as follows:

907.2.3 Group E.

A manual fire alarm system that initiates that occupant notification signal utilizing an emergency voice/alarm communication system meeting the requirements of Section 907.5.2.2 and installed in accordance with Section 907.6 shall be installed in Group E educational occupancies. When automatic sprinkler systems or smoke detectors are installed, such systems or detectors shall be connected to the building fire alarm system. An approved fire alarm system shall be installed in Group E day care occupancies.

Unless separated by a minimum of 100 ft. open space, all buildings, whether portable or permanent buildings, will be considered one building for alarm occupant load consideration and interconnection of alarm systems.

Exceptions:

1. Portable/Temporary buildings in Group E Educational occupancies with manual fire alarm systems are not required to be connected to the alarm system in the main building.
2. Residential in-home day care with not more than 12 children may use interconnected single station detectors in all habitable rooms. (For care of more than five children 2½ or less years of age, see Section 907.2.6.)

79. The amendment of Section 907.2.7, entitled **Group M**, by deleting Section 907.2.7.1, entitled **Occupant notification**, in its entirety.

80. The amendment of section 907.2.10, entitled **Group S**, to read as follows:

907.2.10 Group S.

A manual fire alarm system that activates the occupant notification system in accordance with Section 907.5 shall be installed in Group S public- and self-storage occupancies for interior corridors and interior common areas. Visible notification appliances are not required within storage units.

Exception: Manual fire alarm boxes are not required where the building is equipped throughout with an automatic sprinkler system installed in accordance with Section 903.3.1.1, and the occupant notification appliances will activate throughout the notification zones upon sprinkler water flow.

81. The amendment of Section 907.2.13, entitled **High-rise buildings**, Exception 3, to read as follows:

3. Buildings with an occupancy in Group A-5 in accordance with Section 303.1 of the International Building Code, when used for open air seating; however, this exception does not apply to accessory uses, including but not limited to, sky boxes, restaurants and similarly enclosed areas.

82. The amendment of Section 907.4.2, entitled **Manual fire alarm boxes**, by adding Section 907.4.2.7, entitled **Type**, which shall read as follows:

907.4.2.7 Type.

Manual alarm initiating devices shall be an approved double action type.

83. The amendment of Section 907.5.2.3, entitled **Visible alarms**, by amending Exception 1 to read as follows:

1. The Fire Code Official shall determine if visible alarm notification appliances are required in alterations.

84. The amendment of Section 907.6.1, entitled **Wiring**, by adding Section 907.6.1.1, entitled **Installation**, which shall read as follows:

907.6.1.1 Installation.

All fire alarm systems shall be installed in such a manner that a failure of any single initiating device or single open in an initiating circuit conductor will not interfere with the normal operation of other such devices. All signaling line circuits (SLC) shall be installed in such a way that a single open will not interfere with the operation of any addressable devices. Outgoing and return SLC conductors shall be installed in accordance with NFPA 72 requirements for Class A, Style 6 circuits and shall have a minimum of six

horizontal feet separation and a minimum of one-foot vertical separation between supply and return circuit conductors. The initiating device circuit (IDC) from a signaling line circuit interface device may be wired Class B, provided the distance from the interface device to the initiating device is ten feet or less.

85. The amendment of Section 907.6.3, entitled **Initiating device identification**, by deleting all Exceptions in their entirety.

86. The amendment of Section 907.6.6, entitled **Monitoring**, by adding a second sentence to the section before the Exceptions which shall read as follows:

See Section 907.6.3 for the required information transmitted to the supervising station.

87. The Section 907.6.6., entitled **Monitoring**, by adding Section 907.6.6.4, entitled **Local alarm system**, which shall read as follows:

907.6.6.4 Local alarm system.

When an automatic fire alarm system is not monitored by an approved central station alarm company, an external weatherproof, audible/visual alarm sounding device shall be provided in an approved location with an approved sign, with a minimum of four-inch (4") letters, reading "WHEN ALARM SOUNDS, CALL FIRE DEPARTMENT" adjacent to the alarm-sounding device.

An approved permanent sign reading "LOCAL ALARM ONLY – CALL 9-1-1" shall be provided on or adjacent to the fire alarm control panel and all manual fire alarm pull stations.

88. The amendment of Section 910.2, entitled **Where required.**, to read as follows:

910.2 Where required.

Smoke and heat vents or a mechanical smoke removal system shall be installed as required by Sections 910.2.1, 910.2.2, and 910.3.2.

Exceptions:

1. Frozen food warehouses used solely for storage of Class I and II commodities where protected by an approved automatic sprinkler system.

2. Only manual smoke and heat removal shall not be required in areas of buildings equipped with early suppression fast-response (ESFR) sprinklers. Automatic smoke and heat removal is prohibited.
3. Only manual smoke and heat removal shall not be required in areas of buildings equipped with control mode special application sprinklers with a response time index of $50(m^*S)^{1/2}$ or less that are listed to control a fire in stored commodities with 12 or fewer sprinklers. Automatic smoke and heat removal is prohibited.

89. The amendment of Section 910.2, entitled **Where required**, by adding Section 910.2.3, entitled **Group H**, which shall read as follows:

910.2.3 Group H.

Buildings and portions thereof used as a Group H occupancy as follows:

1. In occupancies classified as Group H-2 or H-3, any of which are more than 15,000 square feet (1394 m²) in single floor area.

Exception: Buildings of noncombustible construction containing only noncombustible materials.

2. In areas of buildings in Group H used for storing Class 2, 3, and 4 liquid and solid oxidizers, Class 1 and unclassified detonable organic peroxides, Class 3 and 4 unstable (reactive) materials, or Class 2 or 3 water-reactive materials as required for a high-hazard commodity classification.

Exception: Buildings of noncombustible construction containing only noncombustible materials.

90. The amendment of Section 910.3.4, entitled **Vent operations**, to read as follows:

910.3.4 Vent operations.

Smoke and heat vents shall be capable of being operated by approved automatic and manual means, unless automatic operation is not allowed by Section 910.2. Automatic operation of smoke and heat vents shall conform to the provisions of Sections 910.3.4.1 and 910.3.4.2.

91. The amendment of Section 910.3.4, entitled **Vent operations**, by adding Section 910.3.4.1, entitled **Sprinklered buildings**, and Section 910.3.4.2, entitled **Non-sprinklered buildings**, which shall read as follows:

910.3.4.1 Sprinklered buildings.

Where installed in buildings equipped with an approved automatic sprinkler system, smoke and heat vents shall be designed to operate automatically. The automatic operating mechanism of the smoke and heat vents shall operate at a temperature rating at least 100 degrees F (approximately 38 degrees Celsius) greater than the temperature rating of the sprinklers installed.

Exception: Manual only systems per Section 910.2.

910.3.4.2 Non-sprinklered buildings.

Where installed in buildings not equipped with an approved automatic sprinkler system, smoke and heat vents shall operate automatically by actuation of a heat-responsive device rated at between 100°F (56°C) and 220°F (122°C) above ambient.

Exception: Listed gravity-operated drop out vents.

92. The amendment of Section 910.4.3.1, entitled **Makeup air**, to read as follows:

910.4.3.1 Makeup air.

Makeup air openings shall be provided within 6 feet (1829 mm) of the floor level. Operation of makeup air openings shall be automatic. The minimum gross area of makeup air inlets shall be 8 square feet per 1,000 cubic feet per minute (0.74 m² per 0.4719 m³/s) of smoke exhaust.

93. The amendment of Section 910.4.4, entitled **Activation**, to read as follows:

910.4.4 Activation. The mechanical smoke removal system shall be activated only automatically by the *automatic sprinkler system* or by an *approved* fire detection system. Individual manual controls shall also be provided.

Exception: Manual only systems per Section 910.2.

94. The amendment of Section 912.2, entitled **Location**, to read as follows:

912.2 Location.

The location of all fire department connections shall be approved by the Fire Code Official. Fire department connections shall be located so that fire apparatus staging and hose connected to the fire department connection will not obstruct access to the building for other fire apparatus. Fire department connection location shall account for obstructions from driveways, buildings, security barriers, fences, and landscaping.

Each automatic sprinkler system shall be equipped with at least one fire department connection. If more than one building is served by a common underground fire main, each building shall have a separate fire department connection. If more than one fire department connection is provided for a common underground fire main or if more than one connection is installed for a building or buildings, the failure of one connection shall not inhibit the usage or operation of other connections, nor shall other buildings be affected by the failure of any single connection.

95. The amendment of Section 912.2, entitled **Location**, by adding Section 912.2.3, entitled **Hydrant distance**, which shall read as follows:

912.2.3 Hydrant distance.

An approved fire hydrant shall be located within 100 feet of the fire department connection as the fire hose lays along an unobstructed path.

96. The amendment of Section 912.2, entitled **Location**, by adding Section 912.2.4, entitled **High-rise buildings**, to read as follows:

912.2.4 High-rise buildings.

All fire department connections for any high-rise building shall be installed within twenty-five feet (25') of an approved street or Fire Lane.

97. The amendment of Section 912.3, entitled **Fire hose threads**, to read as follows:

912.3 Fire hose threads.

All fire department connections within the jurisdiction shall be a 4-inch Storz-type connection. This connection shall be constructed of high-strength, lightweight, corrosion-resistant aluminum alloy capable of being securely attached to the outlets/piping and shall conform to applicable industry standards in regards to design and installation. The hose sealing surface shall consist of a machined metal seat to eliminate rubber gaskets, coated to protect against long term exposure to the environment. The Storz connection shall connect to the pipe outlet using National Standard Thread. The connection shall be angled downward at a 30° angle. An approved locking device shall be installed on each fire department connection.

98. The amendment of Section 913.2.1, entitled Protection of fire pump rooms, by adding Section 913.2.1.1, entitled **Fire Pump Room Access**, and an exception, which shall read as follows:

913.2.1.1 Fire Pump Room Access.

When located on the ground level at an exterior wall, the fire pump room shall be provided with an exterior fire

department access door that is not less than 3 ft. in width and 6 ft. – 8 in. in height, regardless of any interior doors that are provided. A key box shall be provided at this door, as required by IFC Section 506.1.

Exception: When it is necessary to locate the fire pump room on other levels or not at an exterior wall, the corridor leading to the fire pump room access from the exterior of the building shall be provided with equivalent fire resistance as that required for the pump room, or as approved by the fire code official. Access keys shall be provided in the key box as required by IFC Section 506.1.

99. The amendment of Section 913.4, entitled **Valve supervision**, to read as follows:

913.4 Valve supervision.

Where provided, fire pump suction, discharge, and bypass valves, and isolation valves on the backflow prevention device or assembly shall be supervised in accordance with Section 903.4 – as amended.

100. The amendment of Section 915.1.1, entitled **Where required**, by adding a second paragraph which shall read as follows:

Carbon monoxide detection shall be installed for commercial kitchen hoods complying with NFPA 96, in accordance with Section 915.2.4.

101. The amendment of Section 915.2.3, entitled **Group E occupancies**, to read as follows:

915.2.3 Group E occupancies.

Carbon monoxide detection shall be installed in classrooms and other required locations, as determined by the Fire Code Official, in Group E occupancies and shall be tied into the building's fire alarm system in accordance with NFPA 72. Carbon monoxide alarms shall be automatically transmitted to an on-site location that is staffed by school personnel and shall annunciate at the fire alarm control unit as a non-silenceable, latching alarm with a distinct audible and visual alarm.

102. The amendment of Section 915.4, entitled **Carbon monoxide alarms**, by adding Section 915.4.5, entitled **Commercial kitchen hoods**, which shall read as follows:

915.4.5 Commercial kitchen hoods.

Carbon monoxide detection shall be installed in commercial kitchens with new or remodeled hoods complying with Section

606.2 and *NFPA 96*. Carbon monoxide detectors shall be installed in an *approved* location in the kitchen relatively near the fuel-fired gas appliances and in an *approved* location in the dining area, if applicable.

Carbon monoxide detectors shall be interconnected to the fire alarm system and shall report distinctively as such, in accordance with *NFPA 72*. Standalone detectors shall be allowed if the building is not equipped with a fire alarm system; in this instance, local audible notification from the detector(s) is required.

103. The amendment of Section 1006.2.1, entitled **Egress based on occupant load and common path of egress travel distance**, by amending Exception 3 to read as follows:
 3. Unoccupied rooftop mechanical rooms and penthouses are not required to comply with the common path of egress travel distance measurement.
104. The amendment of Section 1009.1, entitled **Accessible means of egress required**, by adding Exception 3, which shall read as follows:
 3. Projects registered with the Architectural Barriers Division of the Texas Department of Licensing and Regulation shall be deemed to be in compliance with the requirements of Section 1009.
105. The amendment of Section 1009.8, entitled **Two way communication**, by adding Exception 7, which shall read as follows:
 7. Buildings regulated under state law and built in accordance with state registered plans, including variances or waivers granted by the State of Texas, shall be deemed to comply with the requirements of Section 1009 (Accessible Means of Egress) and Chapter 11 (Accessibility).
106. The amendment of Section 1010.2.5, entitled **Bolt locks**, by amending Exceptions 3 and 4 to read as follows:
 3. Where a pair of doors serves an occupant load of less than 50 persons in a Group B, F, M or S occupancy, manually operated edge- or surface-mounted bolts are permitted on the inactive leaf. The inactive leaf shall not contain doorknobs, panic bars, or similar operating hardware.
 4. Where a pair of doors serves a Group A, B, F, M or S occupancy, manually operated edge- or surface-mounted bolts are permitted on the inactive leaf, provided that such inactive leaf is not needed to meet egress capacity

requirements and the building is equipped throughout with an automatic sprinkler system in accordance with Section 903.3.1.1. The inactive leaf shall not contain doorknobs, panic bars, or similar operating hardware.

107. The amendment of Section 1010.2.7, entitled **Stairway doors**, by adding Exception 6, which shall read as follows:

6. In stairways serving more than four stories, doors can be locked from stairway side if lock is connected to fire alarm system and key to the door is provided in a Knox Box. Activation of fire alarm system must release locks on all stairway doors.

108. The amendment of Section 1017.3, entitled **Measurement**, by adding Exceptions 3 and 4, which shall read as follows:

3. In other than occupancy Groups H and I, the exit access travel distance to a maximum of 50 percent of the exits is to be measured from the most remote point within a building to an exit using unenclosed exit access stairways or ramps when connecting to a maximum of two stories. The two connected stories shall be provided with at least two means of egress. Such interconnected stories shall not be open to other stories.

4. In other than occupancy Groups H and I, the exit access travel distance to a maximum of 50 percent of the exits is to be measured from the most remote point within a building to an exit using unenclosed exit access stairways or ramps in the first and second stories above grade plane in buildings equipped throughout with an *automatic sprinkler system* in accordance with Section 903.3.1.1. The first and second stories above grade plane shall be provided with at least two means of egress. Such interconnected stories shall not be open to other stories.

109. The amendment of Section 1017, entitled **EXIT ACCESS TRAVEL DISTANCE**, by adding Section 1017.4, entitled **Roof Vent Increase**, which shall read as follows:

1017.4 Roof Vent Increase.

In buildings that are one story in height, equipped with automatic heat and smoke roof vents complying with Section 910 and equipped throughout with an automatic sprinkler system in accordance with Section 903.3.1.1, the maximum exit access travel distance shall be 400 feet for Group F-1 or S-1 occupancies.

110. The amendment of Section 1020.2, entitled **Construction**, by adding Exception 6, which shall read as follows:

6. In unsprinklered group B occupancies, corridor walls and ceilings need not be of fire-resistive construction within a single tenant space when the space is equipped with approved automatic smoke-detection within the corridor. The actuation of any detector must activate self-annunciating alarms audible in all areas within the corridor. Smoke detectors must be connected to an approved automatic fire alarm system where such system is provided.
111. The amendment of Section 1030.1.1.1, entitled **Spaces under grandstands and bleachers**, by adding Exception 4, which shall read as follows:
 4. Where alternate means or methods are submitted to and approved by the Building and Fire Officials.
 112. The amendment of Section 1101.1, entitled **Scope**, by adding an Exception, which shall read as follows:

Exception: Components of projects regulated by and registered with Architectural Barriers Division of Texas Department of Licensing and Regulation shall be deemed to be in compliance with the requirements of this chapter.
 113. The amendment of Section 1612.3, entitled **Establishment of flood hazard areas.**, to read as follows:

1612.3 Establishment of flood hazard areas.
To establish flood hazard areas, the applicable governing authority shall adopt a flood hazard map and supporting data. The flood hazard map shall include, at a minimum, areas of special flood hazard as identified by the Federal Emergency Management Agency in an engineering report entitled "The Flood Insurance Study for Tarrant County, Texas", dated September 25, 2009, as amended or revised with the accompanying Flood Insurance Rate Map (FIRM) and Flood Boundary and Floodway Map (FBFM) and related supporting data along with any revisions thereto. The adopted flood hazard map and supporting data are hereby adopted by reference and declared to be part of this section.
 114. The amendment of Section 1612.3.2, entitled **Determination of impacts**, to read as follows:

1612.3.2 Determination of impacts.
In flood hazard areas where design flood elevations are specified, the applicant shall provide an engineering analysis developed by a licensed professional engineer that demonstrates that the proposed work will not increase the design flood elevation or reduce conveyance at any point within the jurisdiction in accordance with

the provisions of the Design Criteria Manual and the Flood Damage Prevention Chapter of the Arlington City Code.

115. The amendment of Section 1612.2, entitled **Design and construction**, to read as follows:

1612.2 Design and construction.

The design and construction of buildings and structures located in flood hazard areas, including flood hazard areas subject to high-velocity wave action, shall be in accordance with Chapter 5 of ASCE 7 and with ASCE 24 and provisions of the City of Arlington's Flood Damage Prevention Chapter.

116. The amendment of Section 1612.4, entitled **Flood hazard documentation**, to read as follows:

1612.4 Flood hazard documentation.

The flood hazard documentation as identified in the City of Arlington's Flood Damage Chapter shall be prepared and sealed by a professional engineer and submitted to the building official.

117. The amendment of Section 1704.2, entitled **Special inspections and tests**, to read as follows:

1704.2 Special inspections and tests.

Where application is made to the Building Official for construction as specified in Section 105, the owner or the owner's authorized agent, or the registered design professional in responsible charge, other than the contractor, shall employ one or more approved agencies to provide special inspections and tests during construction on the types of work listed under Section 1705 and identify the approved agencies to the Building Official. The special inspector shall not be employed by the contractor. These special inspections and tests are in addition to the inspections identified by the Building Official that are identified in Section 110.

118. The amendment of Section 1704.2.1, entitled **Special inspector qualifications**, is amended to read as follows:

1704.2.1 Special inspector qualifications.

Prior to the start of construction and or upon request, the approved agencies shall provide written documentation to the registered design professional in responsible charge and the building official demonstrating the competence and relevant experience or training of the special inspectors who will perform the special inspections and tests during construction. Experience or training shall be considered to be relevant where the documented experience or training is related in complexity to the same type of special inspection or testing activities for projects of similar complexity and

material qualities. These qualifications are in addition to qualifications specified in other sections of this code.

The registered design professional in responsible charge and engineers of record involved in the design of the project are permitted to act as an approved agency and their personnel are permitted to act as special inspectors for the work designed by them, provided they qualify as special inspectors.

119. The amendment of Section 1704.2.4, entitled **Report requirement**, is amended to read as follows:

1704.2.4 Report requirement.

Approved agencies shall keep records of special inspections and tests. The approved agency shall submit reports of special inspections and tests to the Building Official upon request, and to the registered design professional in responsible charge. Individual inspection reports shall indicate that work inspected or tested was or was not completed in conformance to approved construction documents. Discrepancies shall be brought to the immediate attention of the contractor for correction. If they are not corrected, the discrepancies shall be brought to the attention of the building official and to the registered design professional in responsible charge prior to the completion of that phase of the work. A final report documenting required special inspections and tests, shall be submitted at a point in time agreed upon prior to the start of work by the owner or the owner's authorized agent to the building official.

120. The amendment of Section 1704.2.5.1, entitled **Fabricator approval**, to read as follows:

1704.2.5.1 Fabricator approval.

Special inspections during fabrications required by Section 1704 are not required where the work is done on the premises of a fabricator registered and approved to perform such work without special inspection. Approval shall be based upon review of the fabricator's written procedural and quality control manuals and periodic auditing of fabrication practices by an approved agency, or a fabricator that is enrolled in a nationally accepted inspections program. At completion of fabrication, the acceptable or approved fabricator shall submit a certificate of compliance to the owner or the owner's authorized agent or the registered design professional in responsible charge, for submittal to the building official as specified in Section 1704.5 stating that the work was performed in accordance with the approved construction documents. The certificate of

compliance shall also be made available to the Building Official upon request.

121. The amendment of Section 1807.2, entitled **Retaining walls.**, to read as follows:

1807.2 Retaining walls.

Retaining walls exceeding four feet (4') in developed height (the height from the base of the foundation to the top of the wall) at any point shall be designed by a professional engineer. A wall built in tiers shall be considered a single wall in developed height when the base of the upper tier is set back from the base of the lower tier less than one and one-half (1½) times the developed height of the wall section below. Walls supporting an imposed load such as a building, driveway or other permanent construction closer to the wall than one and one-half (1½) times the developed height of the wall shall be designed by a professional engineer.

When required to be designed by an engineer the design shall be in accordance with Sections 1807.2.1 through 1807.2.3.

122. The amendment of Section 1809.5.1, entitled **Frost Protection at required exits**, by deleting the section in its entirety.

123. The amendment of Section 2702, entitled **EMERGENCY AND STANDBY POWER SYSTEMS**, by adding Section 2702.5, entitled **Designated Critical Operations Areas (DCOA)**, which shall read as follows:

Section 2702.5 Designated Critical Operations Areas (DCOA)

In areas within a facility or site requiring continuous operation for the purpose of public safety, emergency management, national security or business continuity, the power systems shall comply with NFPA 70 Article 708.

124. The amendment of Section 2901.1, entitled **Scope**, by adding the following sentence, which shall read as follows:

The provisions of this Chapter are meant to work in coordination with the provisions of Chapter 4 of the International Plumbing Code. Should any conflicts arise between the two chapters, the Building Official shall determine which provision applies.

125. The amendment of Section 2902.1, entitled **Minimum number of fixtures**, by adding a second paragraph which shall read as follows:

In other than E Occupancies, the minimum number of fixtures in Table 2902.1 may be lowered, if requested in writing, by the applicant stating reasons for a reduced number and approved by the Building Official.

126. The amendment of Table 2902.1, entitled **MINIMUM NUMBER OF REQUIRED PLUMBING FIXTURES**, by adding footnote g, which shall read as follows:

g. Drinking fountains are not required in M Occupancies with an occupant load of 100 or less, B Occupancies with an occupant load of 25 or less, and for dining and/or drinking establishments.

127. The amendment of Section 2902.1, entitled **Minimum number of fixtures**, by adding Section 2902.1.4, et seq, which shall read as follows:

2902.1.4 Additional fixtures for food preparation facilities.

In addition to the fixtures required in this Chapter, all food service facilities shall be provided with additional fixtures set out in this section.

2902.1.4.1 Hand washing lavatory.

At least one hand washing lavatory shall be provided for use by employees that is accessible from food preparation, food dispensing and ware washing areas. Additional hand washing lavatories may be required based on convenience of use by employees.

2902.1.4.2 Service sink.

In new or remodeled food service establishments, at least one service sink or one floor sink shall be provided so that it is conveniently located for the cleaning of mops or similar wet floor cleaning tool and for the disposal of mop water and similar liquid waste. The location of the service sink(s) and/or mop sink(s) shall be approved by the City of Arlington health department.

128. The amendment of Section 2902.2, entitled **Separate facilities**, by deleting Exception 6 in its entirety.
129. The amendment of Section 3002.1, entitled **Hoistway enclosure protection**, by adding the following Exceptions:

Exceptions:

1. Elevators completely located within atriums shall not require hoistway enclosure protection.
2. Elevators in open or enclosed parking garages that serve only the parking garage, shall not require hoistway enclosure protection.

130. The amendment of Section 3005.4, entitled **Machine rooms, control rooms, machinery spaces and control spaces**, by deleting the 2 existing exceptions and replacing them with the following:

Exceptions:

1. Elevator machine rooms, control rooms, machinery spaces and control spaces completely located within atriums shall not require enclosure protection.
 2. Elevator machine rooms, control rooms, machinery spaces and control spaces in open or enclosed parking garages that serve only the parking garage, shall not require enclosure protection.
131. The amendment of Section 3005.5, entitled **Shunt trip**, by adding Section 3005.5.1, et seq., which shall read as follows:

3005.5.1 Fire Protection in Machine rooms, control rooms, machinery spaces and control spaces.

3005.5.1.1 Automatic sprinkler system.

The building shall be equipped throughout with an automatic sprinkler system in accordance with Section 903.3.1.1, except as otherwise permitted by Section 903.3.1.1.1 and as prohibited by Section 3005.5.1.1.1.

3005.5.1.1.1 Prohibited locations.

Automatic sprinklers shall not be installed in machine rooms, elevator machinery spaces, control rooms, control spaces and elevator hoistways.

3005.5.1.1.2 Sprinkler system monitoring.

The sprinkler system shall have a sprinkler control valve supervisory switch and water-flow initiating device provided for each floor that is monitored by the building's fire alarm system.

3005.5.1.2 Water protection.

An approved method to prevent water from infiltrating into the hoistway enclosure from the operation of the automatic sprinkler system outside the elevator lobby shall be provided.

3005.5.1.3 Omission of Shunt trip.

Means for elevator shutdown in accordance with Section 3005.5 shall not be installed.

132. The amendment of Section 3005, entitled **MACHINE ROOMS**, by adding Section 3005.7, entitled **Storage**, which shall read as follows:

3005.7 Storage.

Storage shall not be allowed within the elevator machine room, control room, machinery spaces and or control spaces. Provide approved signage at each entry to the above listed locations stating: "No Storage Allowed".

133. The amendment of Section 3006.2, **Hoistway opening protection required**, by replacing Condition 5 with the following:

5. The building is a high rise and the elevator hoistway is more than 75 feet (22 860 mm) in height. The height of the hoistway shall be measured from the lowest floor at or above grade to the highest floors served by the hoistway."

134. The amendment of Section 3007.3, entitled **Water protection**, to read as follows:

3007.3 Water Protection.

Water from the operation of an automatic sprinkler system outside the lobby shall be prevented from infiltrating into the hoistway enclosure in accordance with an approved method.

135. The amendment of Section 3008.3, entitled **Water protection**, to read as follows:

3008.3 Water Protection.

Water from the operation of an automatic sprinkler system outside the lobby shall be prevented from infiltrating into the hoistway enclosure in accordance with an approved method.

- D. The following local amendments to the International Residential Code (I.R.C.) are hereby adopted:

1. The amendment of Section R101.1, entitled **Title**, to read as follows:

R101.1 Title.

These provisions shall be known as the Residential Code for One- and Two-family Dwellings of the City of Arlington, Texas, and shall be cited as such and will be referred to herein as "this code."

2. The amendment of Section R102.4, entitled **Referenced codes and standards**, to read as follows:

R102.4 Referenced codes and standards.

The codes, when specifically adopted, and standards referenced in this code shall be considered part of the requirements of this code to the prescribed extent of each such reference. Whenever amendments have been adopted to the referenced codes and standards, each reference to said code and

standards shall be considered to reference the amendments as well. Any reference made to NFPA 70, or ICC Electrical Code shall mean the Electrical Code as adopted.

Where differences occur between provisions of this code and referenced codes and standards, the provisions of this code shall apply.

Exception: Where enforcement of a code provision would violate the conditions of the listing of the equipment or appliance, the conditions of the listing and manufacturer's instructions shall apply.

3. The amendment of Section R104.10.1, entitled **Flood hazard areas**, by deleting the section in its entirety.
4. The deletion of Section R105, entitled **PERMITS**, in its entirety.
5. The deletion of Section R106, entitled **CONSTRUCTION DOCUMENTS**, in its entirety.
6. The deletion of Section R108, entitled **FEES**, in its entirety.
7. The deletion of Section R109, entitled **INSPECTIONS**, in its entirety.
8. The deletion of Section R110, entitled **CERTIFICATE OF OCCUPANCY**, in its entirety.
9. The deletion of Section R112, entitled **BOARD OF APPEALS**, in its entirety.
10. The deletion of Section R113, entitled **VIOLATIONS**, in its entirety.
11. The amendment of Section R114, entitled **STOP WORK ORDER**, to read as follows:

SECTION R114 STOP WORK ORDER

R114.1 Stop Work Order.

Whenever any work is being done contrary to the provisions of this Code, the Building Official may order the work stopped by notice in writing served on any persons engaged in the doing or causing such work to be done. Any such person shall forthwith stop such work until:

- a. He or she is authorized by the Building Official to proceed with the work; or

- b. An appeal perfected pursuant to Section 2.06 of Article II has resulted in a waiver of the condition causing the stop order, or a finding that there is no cause for a stop order.

Failure to stop such work, in addition to penalties and remedies elsewhere set forth, shall void any appeal.

12. The amendment of Section R202, entitled DEFINITIONS, by amending the definition of **TOWNHOUSE UNIT** to read as follows:

TOWNHOUSE UNIT. A single-family dwelling unit separated by property lines in a townhouse that extends from foundation to roof and that has a yard or public way on not less than two sides.

13. The amendment of Table R301.2, entitled **CLIMATIC AND GEOGRAPHIC DESIGN CRITERIA**, by filling in the local criteria as follows:

GROUND SNOW LOAD	WIND DESIGN				SEISMIC DESIGN CATEGORY ^f A	SUBJECT TO DAMAGE FROM			WINTER DESIGN TEMP ^e	ICE BARRIER UNDER-LAYMENT ^h	FLOOD HAZARDS ^g	AIR FREEZING INDEX ⁱ	MEAN ANNUAL TEMP ^j
	SPEED ^d (MPH)	Topographic Effects ^k	Special Wind Region ^l	Windborne Debris Zone ^m		Weathering ^{g a}	Frost Line Depth ^b	Termite ^c					
5 lb/ft	115 (3 sec-gust)/ 76 fastest mile	No	No	No		Moderate	6"	Very Heavy	22° F	No	Local Code	150	64.9° F

{Delete remainder of table Manual J Design Criteria and footnote N}

14. The amendment of Section R302.1, entitled **Exterior walls**, by adding Exception 6, which shall read as follows:

6. Open non-combustible carport structures may be constructed when also approved within adopted ordinances.

15. The amendment of Section R302.2.6, entitled **Structural independence**, by deleting Exception 6 in its entirety.

16. The amendment of Section R302.3, entitled **Two-family dwellings**, by adding Exception 3, which shall read as follows:

3. Two-family dwelling units that are also divided by a property line through the structure shall be separated as required for townhouses.

17. The amendment of Section R302.5.1, entitled **Opening protection**, to read as follows:

R302.5.1 Opening protection.

Openings from a private garage directly into a room used for sleeping purposes shall not be permitted. Other openings between the garage and residence shall be equipped with solid wood doors not less than 13/8 inches (35 mm) in thickness, solid or honeycomb core steel doors not less than 13/8 inches (35 mm) thick, or 20-minute fire-rated doors.

18. The amendment of Section R303.3, entitled **Bathrooms**, by amending the Exception to add the following sentence:

Spaces containing only a water closet or water closet and a lavatory may be ventilated with an approved mechanical recirculating fan or similar device designed to remove odors from the air.

19. The amendment of Section R307, entitled **TOILET, BATH AND SHOWER SPACES**, by adding R307.3, entitled **Blocking**, which shall read as follows:

R307.3 Blocking.

Required at one toilet at grade level. Blocking per Sec. R307.4 and Figure 307.4, shall be installed at rear wall and one wall adjacent to toilet at the lowest living level where a toilet is provided.

20. The amendment of Section R307, entitled **TOILET, BATH AND SHOWER SPACES**, by adding R307.4, entitled **Blocking**

R307.4 Blocking.

Blocking may be 1/2" plywood or equivalent or 2 x solid wood blocking flush with wall.

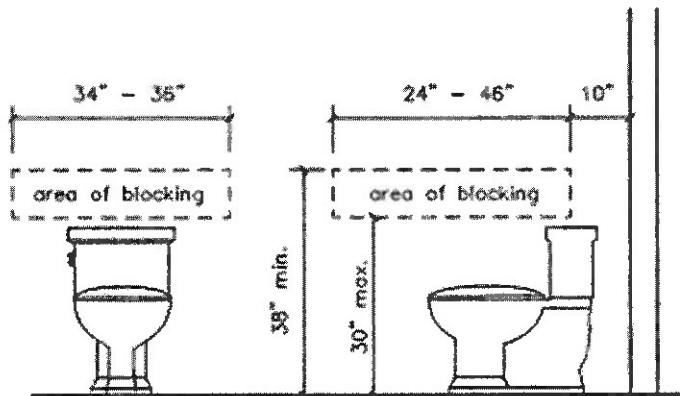

Figure 307.4

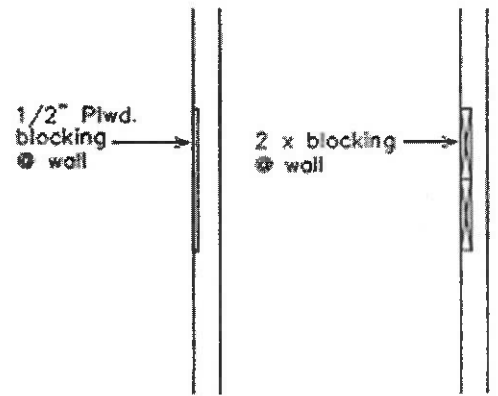

Figure 307.4

21. The amendment of Section R313.2, entitled **One- and two-family dwellings automatic sprinkler systems**, by deleting the section in its entirety.
22. The amendment of Section R315.2.2, entitled **Alterations, repairs and additions**, by amending Exception 2 to read as follows:
 2. Installation, alteration or repairs of all electrically powered mechanical systems or plumbing appliances.
23. The amendment of Section R322, entitled **FLOOD RESISTANT CONSTRUCTION**, by deleting the section in its entirety.
24. The amendment of Section R327, entitled **SWIMMING POOLS, SPAS AND HOT TUBS**, Section R327.1, entitled **General**, by adding Section R327.1.1, entitled **Adjacency to Structural Foundation**, which shall read as follows:

R327.1.1 Adjacency to Structural Foundation.
Depth of the swimming pool and spa shall maintain a ratio of 1:1 from the nearest building foundation or footing of a retaining wall.

Exception:
A sealed engineered design drawing of the proposed new structure shall be submitted for approval.
25. The amendment of Section R401.2, entitled **Requirements**, by adding a second and third paragraph which shall read as follows:

Every foundation and/or footing, or any size addition to an existing post-tension foundation, regulated by this code shall be designed and sealed by a Texas-registered engineer.

Foundations for the construction of new 1- and 2-family homes and foundations for additions to existing 1- and 2-family homes shall be designed by an engineer licensed by the State of Texas.
26. The amendment of Section R602.6.1, entitled **Drilling and notching of top plate**, by amending the first paragraph to read as follows:

R602.6.1 Drilling and notching of top plate.
When piping or ductwork is placed in or partly in an exterior wall or interior load-bearing wall, necessitating cutting, drilling or notching of the top plate by more than 50 percent of its width, a galvanized metal tie not less than 0.054 inch thick (1.37 mm) (16 Ga) and 5 inches (127 mm) wide shall be fastened across and to the

plate at each side of the opening with not less than eight 10d (0.148 inch diameter) having a minimum length of 1 ½ inches (38 mm) at each side or equivalent. Fasteners will be offset to prevent splitting of the top plate material. The metal tie must extend a minimum of 6 inches past the opening. See figure R602.6.1.

27. The amendment of Figure R602.6.1, entitled **TOP PLATE FRAMING TO ACCOMMODATE PIPING**, by deleting the figure and replacing same with the following figure:

WALL CONSTRUCTION

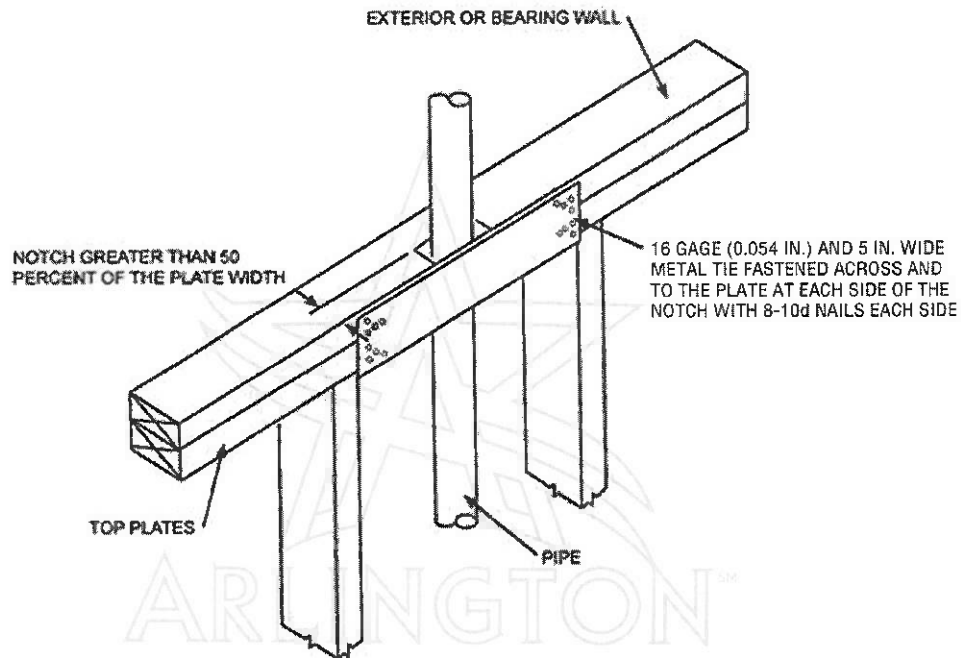

For SI: 1 inch = 25.4 mm

FIGURE R602.6.1
TOP PLATE FRAMING TO ACCOMMODATE PIPING

28. The amendment of Section R703.8.4.1, entitled **Size and spacing**, by adding Section R703.8.4.1.2, entitled **Veneer ties for wall studs**, which shall read as follows:

R703.8.4.1.2 Veneer Ties for Wall Studs.

In stud framed exterior walls, all ties may be anchored to studs as follows:

1. When studs are 16 in (407 mm) o.c., stud ties shall be spaced no further apart than 24 in

(737 mm) vertically starting approximately 12 in (381 mm) from the foundation; or

2. When studs are 24 in (610 mm) o.c., stud ties shall be spaced no further apart than 16 in (483 mm) vertically starting approximately 8 in (254 mm) from the foundation.

29. The amendment of Section R902.1, **Roof covering materials**, by amending the first paragraph to read as follows:

R902.1 Roofing covering materials.

Roofs shall be covered with materials as set forth in Sections R904 and R905. Class A, B, or C roofing shall be installed. Class A, B and C roofing required by this section to be listed shall be tested in accordance with ASTM E108 and UL 790.

30. The amendment of Section R902.1, **Roof covering materials**, by adding Exception 5, which shall read as follows:

5. Non-classified roof coverings shall be permitted on one-story detached accessory structures used as tool and storage sheds, playhouses, and similar uses, provided the floor area does not exceed 120 square feet.

31. The amendment of Chapter 11, entitled **[RE] Energy Efficiency**, by deleting the Chapter in its entirety. Reference the 2021 IECC for energy code provisions and recommended amendments.

32. The amendment of Section M1305.1.2, entitled **Appliances in attics**, to read as follows:

M1305.1.2 Appliances in attics.

Attics containing appliances shall be provided with an opening and unobstructed passageway large enough to allow removal of the largest appliance. The passageway shall be not less than 30 inches (762 mm) high and 22 inches (559 mm) wide and not more than 20 feet (6096 mm) in length measured along the centerline of the passageway from the opening to the appliance. The passageway shall have continuous solid flooring not less than 24 inches (610 mm) wide. A level service space not less than 30 inches (762 mm) deep and 30 inches (762 mm) wide shall be present at the front or service side of the appliance. The clear access opening dimensions shall be a minimum of 20 inches by 30 inches (508 mm by 762 mm), or larger where such dimensions are not large enough to allow removal of the largest appliance. A walkway to an appliance shall be rated as a floor as approved by the building official. As a minimum, for access to the attic space, provide one of the following:

1. A permanent stair.
2. A pull down stair with a minimum 300 lb. (136 kg) capacity.
3. An access door from an upper floor level.
4. Access Panel may be used in lieu of items 1, 2, and 3 with prior approval of the code official due to building conditions.

Exceptions:

1. The passageway and level service space are not required where the appliance is capable of being serviced and removed through the required opening.
2. Where the passageway is unobstructed and not less than 6 feet (1829 mm) high and 22 inches (559 mm) wide for its entire length, the passageway shall be not greater than 50 feet (15 250 mm) in length.

33. The amendment of Section M1411.3, entitled **Condensate disposal**, to read as follows:

M1411.3 Condensate disposal.

Condensate from all cooling coils and evaporators shall be conveyed from the drain pan outlet to a permanently wet p-trap. Condensate shall not discharge in a publicly exposed area such as into a street, alley, sidewalk or other areas so as to cause a nuisance.

Exceptions:

1. Condensate may discharge directly to a roof drain that connects to an underground storm sewer system,
2. Condensate may discharge directly onto roofs covered with membrane type roof coverings where the condensate will drain to a roof drain that connects to an underground storm sewer system,
3. Condensate may discharge to a landscaped area containing flowers and other bedding plants other than turf. There must be five square feet of landscaped area for each ton of refrigeration, or
4. Condensate may discharge to a French drain consisting of a pit excavated below grade that is not less than 24 inches (610 mm) in any dimension. The pit shall be filled with coarse gravel and the drainpipe shall extend into the pit and be securely anchored. A single drain shall not receive the condensate discharge of more than

10 tons nominal of combined cooling capacity. The pit shall be covered with sod after inspection. The French drain shall not be located so that it will receive direct discharge from a roof or a downspout.

34. The amendment of Section M1411.3.1, entitled **Auxiliary and secondary systems**, by amending Items 3 and 4 to read as follows:

3. An auxiliary drain pan without a separate drain line shall be installed under the coils on which condensation will occur. This pan shall be equipped with a water level detection device conforming to UL 580 that will shut off the equipment served prior to overflow of the pan. The pan shall be equipped with a fitting to allow for drainage. The auxiliary drain pan shall be constructed in accordance with Item 1 of this section. A water level detection device may be installed only with prior approval of the building official.
4. A water level detection device conforming to UL 580 shall be installed that will shut off the equipment served in the event that the primary drain is blocked. The device shall be installed in the primary drain line, the overflow drain line or the equipment-supplied drain pan, located at a point higher than the primary drain line connection and below the overflow rim of such pan. A water level detection device may be installed only with prior approval of the building official.

35. The amendment of Section M1411.3.1.1, entitled **Water-level monitoring devices**, to read as follows:

M1411.3.1.1 Water-level monitoring devices.

On down-flow units and other coils that do not have secondary drain or provisions to install a secondary or auxiliary drain pan, a water-level monitoring device shall be installed inside the primary drain pan. This device shall shut off the equipment served in the event that the primary drain becomes restricted. Devices shall not be installed in the drain line. A water level detection device may be installed only with prior approval of the building official.

36. The amendment of Section M1503.6, entitled **Makeup air required**, to read as follows:

M1503.6 Makeup air required.

Where one or more gas, liquid or solid fuel-burning appliance that is neither direct-vent nor uses a mechanical draft venting system is located within a dwelling unit's air barrier, each exhaust system capable of exhausting in excess of 400 cubic feet per minute (0.19 m³/s) shall be mechanically or

passively provided with makeup air at a rate approximately equal to the difference between exhaust air rate and 400 cubic feet per minute. Such makeup air systems shall be equipped with not fewer than one damper complying with Section M1503.6.2.

Exception: Makeup air is not required for exhaust systems installed for the exclusive purpose of space cooling and intended to be operated only when windows or other air inlets are open. Where all appliances in the house are of sealed combustion, power-vent, unvented, or electric, the exhaust hood system shall be permitted to exhaust up to 600 cubic feet per minute (0.28 m³/s) without providing makeup air. Exhaust hood systems capable of exhausting in excess of 600 cubic feet per minute (0.28 m³/s) shall be provided with a makeup air at a rate approximately equal to the difference between the exhaust air rate and 600 cubic feet per minute.

37. The amendment of Section M2005.2, entitled **Prohibited locations**, to read as follows:

M2005.2 Prohibited locations.

Fuel-fired water heaters shall not be installed in a room used as a storage closet. Water heaters located in a bedroom or bathroom shall be installed in a sealed enclosure so that combustion air will not be taken from the living space. Access to such enclosure may be from the bedroom or bathroom when through a solid door, weather-stripped in accordance with the exterior door air leakage requirements of the International Energy Conservation Code and equipped with an approved self-closing device. Installation of direct-vent water heaters within an enclosure is not required.

38. The amendment of Section G2408.3 (305.5), entitled **Private Garages**, by deleting the section in its entirety.
39. The amendment of Section G2415.2 (404.2), entitled **CSST**, by adding a second paragraph which shall read as follows:

Both ends of each section of medium pressure gas piping shall identify its operating gas pressure with an approved tag. The tags are to be composed of aluminum or stainless steel and the following wording shall be stamped into the tag:

"WARNING: 1/2 to 5 psi gas pressure - Do Not Remove"

40. The amendment of Section G2415.12 (404.12), entitled **Minimum burial depth**, to read as follows:

G2415.12 (404.12) Minimum burial depth.

Underground piping systems shall be installed a minimum depth 18 inches (457 mm) below grade.

41. The amendment of Section G2415.12.1 (404.12.1), entitled **Individual outdoor appliances**, by deleting the section in its entirety.

42. The amendment of Section G2417.1 (406.1), entitled **General**, to read as follows:

G2417.1 (406.1) General.

Prior to acceptance and initial operation, all piping installations shall be inspected and pressure tested to determine that the materials, design, fabrication, and installation practices comply with the requirements of this code. The permit holder shall make the applicable tests prescribed in Sections 2417.1.1 through 2417.1.5 to determine compliance with the provisions of this code. The permit holder shall give reasonable advance notice to the building official when the piping system is ready for testing. The equipment, material, power and labor necessary for the inspections and test shall be furnished by the permit holder and the permit holder shall be responsible for determining that the work will withstand the test pressure prescribed in the following tests.

43. The amendment of Section G2417.4 (406.4), entitled **Test pressure measurement**, to read as follows:

G2417.4 (406.4) Test pressure measurement.

Test pressure shall be measured with a monometer or with a pressure-measuring device designed and calibrated to read, record, or indicate a pressure loss caused by leakage during the pressure test period. The source of pressure shall be isolated before the pressure tests are made.

44. The amendment of Section G2417.4.1 (406.4.1), entitled **Test pressure**, to read as follows:

G2417.4.1 (406.4.1) Test pressure.

The test pressure to be used shall be no less than 3 psig (20 kPa gauge), or at the discretion of the Code Official, the piping and valves may be tested at a pressure of at least six (6) inches (152 mm) of mercury, measured with a manometer or slope gauge. For tests requiring a pressure of 3 psig, diaphragm gauges shall utilize a dial with a minimum diameter of three and one half inches (3 ½"), a set hand, 1/10 pound incrementation and pressure range not to exceed 6 psi for tests requiring a pressure of 3 psig. For tests requiring a pressure of 10 psig, diaphragm gauges shall utilize a dial with a minimum diameter of three and one-half inches (3 ½"), a set hand, a minimum of 2/10 pound incrementation and a pressure range not to exceed 20 psi. For welded piping, and for piping carrying gas at pressures in excess of fourteen (14) inches water column pressure (3.48 kPa) (1/2 psi) and less than 200 inches of water column pressure (52.2 kPa) (7.5 psi), the test pressure shall not be less than ten (10) pounds per square inch (69.6 kPa). For piping carrying gas

at a pressure that exceeds 200 inches of water column (52.2 kPa) (7.5 psi), the test pressure shall be not less than one and one-half times the proposed maximum working pressure.

Diaphragm gauges used for testing must display a current calibration and be in good working condition. The appropriate test must be applied to the diaphragm gauge used for testing.

45. The amendment of Section G2417.4.2 (406.4.2), entitled **Test duration**, to read as follows:

G2417.4.2 (406.4.2) Test duration.

The test duration shall be held for a length of time satisfactory to the Building Official, but in no case for less than fifteen (15) minutes. For welded piping, and for piping carrying gas at pressures in excess of fourteen (14) inches water column pressure (3.48 kPa), the test duration shall be held for a length of time satisfactory to the Building Official, but in no case for less than thirty (30) minutes.

46. The amendment of Section G2420.1 (406.1), entitled **General**, by adding Section G2420.1.4, entitled **Valves in CSST installations**, which shall read as follows:

G2420.1.4 Valves in CSST installations.

Shutoff valves installed with corrugated stainless steel (CSST) piping systems shall be supported with an approved termination fitting, or equivalent support, suitable for the size of the valves, of adequate strength and quality, and located at intervals so as to prevent or damp out excessive vibration but in no case greater than 12-inches from the center of the valve. Supports shall be installed so as not to interfere with the free expansion and contraction of the system's piping, fittings, and valves between anchors. All valves and supports shall be designed and installed so they will not be disengaged by movement of the supporting piping.

47. The amendment of Section G2420.5.1 (409.5.1), entitled **Located within the same room**, to read as follows:

G2420.5.1 (409.5.1) Located within the same room.

The shutoff valve shall be located in the same room as the appliance. The shutoff valve shall be within 6 feet (1829 mm) of the appliance, and shall be installed upstream of the union, connector or quick disconnect device it serves. Such shutoff valves shall be provided with access. Shutoff valves serving movable appliances, such as cooking appliances and clothes dryers, shall be considered to be provided with access where installed behind such appliances. Appliance shutoff valves located in the firebox of a fireplace shall be installed in accordance with the appliance manufacturer's instructions. A secondary shutoff valve must be installed within 3 feet (914 mm) of the firebox if appliance shutoff is located in the firebox.

48. The amendment of Section G2421.1 (410.1), entitled **Pressure regulators**, to read as follows:

G2421.1 (410.1) Pressure regulators.

A line pressure regulator shall be installed where the appliance is designed to operate at a lower pressure than the supply pressure. Line gas pressure regulators shall be listed as complying with ANSI Z21.80. Access shall be protected from physical damage. Regulators installed on the exterior of the building shall be approved for outdoor installation. Access to regulators shall comply with the requirements for access to appliances as specified in Section M1305.

Exception: A passageway or level service space is not required when the regulator is capable of being serviced and removed through the required attic opening.

49. The amendment of Section G2422.1.2.3 (411.1.3.3), entitled **Prohibited locations and penetrations**, by deleting Exception 1 and Exception 4.

50. The amendment of Section G2445.2 (621.2), entitled **Prohibited use**, to read as follows:

G2445.2 (621.2) Prohibited use.

One or more unvented room heaters shall not be used as the sole source of comfort heating in a dwelling unit.

Exception: Existing approved unvented room heaters may continue to be used in dwelling units, in accordance with the code provisions in effect when installed, when approved by the Building Official unless an unsafe condition is determined to exist as described in International Fuel Gas Code Section 108.7.

51. The amendment of Section G2448.1.1 (624.1.1), entitled **Installation requirements**, to read as follows:

G2448.1.1 (624.1.1) Installation requirements.

The requirements for water heaters relative to access, sizing, relief valves, drain pans and scald protection shall be in accordance with this code.

52. The amendment of Section P2603.3, entitled **Protection against corrosion**, to read as follows:

P2603.3 Protection against corrosion.

Metallic piping, except for cast iron, ductile iron and galvanized steel, shall not be placed in direct contact with steel framing members, concrete or cinder walls and floors or other masonry. Metallic piping shall not be placed

in direct contact with corrosive soil. Where sheathing is used to prevent direct contact, the sheathing shall have a thickness of not less than 0.008 inch (8 mil) (0.203 mm) and the sheathing shall be made of approved material. Where sheathing protects piping that penetrates concrete or masonry walls or floors, the sheathing shall be installed in a manner that allows movement of the piping within the sheathing.

53. The amendment of Section P2603.5.1, entitled **Sewer depth**, to read as follows:

P2603.5.1 Sewer depth.

Building sewers that connect to private sewage disposal systems shall be a minimum of 12 inches (304 mm) below finished grade at the point of septic tank connection. Building sewers shall be a minimum of 12 inches (304 mm) below grade.

54. The amendment of Section P2604, entitled **TRENCHING AND BACKFILLING**, by adding Section P2604.2.1, entitled **Plastic sewer and DWV piping installation**, which shall read as follows:

P2604.2.1 Plastic sewer and DWV piping installation.

Plastic sewer and DWV piping installed underground shall be installed in accordance with the manufacturer's installation instructions. Trench width shall be controlled to not exceed the outside the pipe diameter plus 16 inches or in a trench which has a controlled width equal to the nominal diameter of the piping multiplied by 1.25 plus 12 inches. The piping shall be bedded in 4 inches of granular fill and then backfilled compacting the side fill in 6-inch layers on each side of the piping. The compaction shall be to minimum of 85 percent standard proctor density and extend to a minimum of 6 inches above the top of the pipe.

55. The amendment of Section P2801.6, entitled **Required pan**, to read as follows:

P2801.6 Required pan.

Where a storage tank-type water heater or a hot water storage tank is installed in a location where water leakage from the tank will cause damage, the tank shall be installed in a pan constructed of one of the following:

1. Galvanized steel or aluminum of not less than 0.0236 inch (0.6010 mm) in thickness.
2. Plastic not less than 0.036 inch (0.9 mm) in thickness.
3. Other approved materials.

56. The amendment of Section P2801.6.1, entitled **Pan size and drain**, to read as follows:

P2801.6.1 Pan size and drain.

The pan shall be not less than 1 1/2 inches (38 mm) in depth and shall be of sufficient size and shape to receive all dripping or condensate from the tank or water heater. The pan shall be drained by an indirect waste pipe having a diameter of not less than 3/4 inch (19 mm). Piping for safety pan drains shall be of those materials listed in Table P2906.5.

Multiple pan drains may terminate to a single discharge piping system when approved by the administrative authority and permitted by the manufactures installation instructions and installed with those instructions. Where a pan drain was not previously installed, a pan drain shall not be required for a replacement water heater installation.

57. The amendment of Section P2804.6.1, entitled **Requirements for discharge piping**, to read as follows:

P2804.6.1 Requirements for discharge piping.

The discharge piping serving a pressure relief valve, temperature relief valve or combination thereof shall:

1. Not be directly connected to the drainage system.
2. Discharge through an air gap located in the same room as the water heater.
3. Not be smaller than the diameter of the outlet of the valve served and shall discharge full size to the air gap.
4. Serve a single relief device and shall not connect to piping serving any other relief device or equipment.

Exception: Multiple relief devices may be installed to a single T & P discharge piping system when approved by the administrative authority and permitted by the manufacturer's installation instructions and installed with those instructions.

5. Discharge to the floor, to the pan serving the water heater or storage tank, to a waste receptor, to an approved location, or to the outdoors.

[Items 6 through 14 remain unchanged]

58. The amendment of Section P2902.5.3, entitled **Lawn irrigation systems**, to read as follows:

P2902.5.3 Lawn irrigation systems.

The potable water supply to lawn irrigation systems shall be protected against backflow by an atmospheric-type vacuum breaker, a pressure-type vacuum breaker, a double-check assembly or a reduced pressure principle backflow preventer. A valve shall not be installed downstream from an atmospheric vacuum breaker. Where chemicals are introduced into the system, the potable water supply shall be protected against backflow by a reduced pressure principle backflow preventer.

59. The amendment of Section P3003.9.2, entitled **Solvent cementing**, to read as follows:

P3003.9.2 Solvent cementing.

Joint surfaces shall be clean and free from moisture. A purple primer that conforms to ASTM F 656 shall be applied. Solvent cement not purple in color and conforming to ASTM D 2564, CSA B137.3, CSA B181.2 or CSA B182.1 shall be applied to all joint surfaces. The joint shall be made while the cement is wet and shall be in accordance with ASTM D 2855. Solvent cement joints shall be permitted above or below ground.

60. The amendment of Section P3111, entitled **COMBINATION WASTE AND VENT SYSTEM**, by deleting the section in its entirety.

61. The amendment of Section P3112.2, entitled **Vent Connection**, by deleting and replacing said Section with the following:

P3112.2 Installation.

Traps for island sinks and similar equipment shall be roughed in above the floor and may be vented by extending the vent as high as possible, but not less than the drainboard height and then returning it downward and connecting it to the horizontal sink drain immediately downstream from the vertical fixture drain. The return vent shall be connected to the horizontal drain through a wye-branch fitting and shall, in addition, be provided with a foot vent taken off the vertical fixture vent by means of a wye-branch immediately below the floor and extending to the nearest partition and then through the roof to the open air or may be connected to other vents at a point not less than six (6) inches (152 mm) above the flood level rim of the fixtures served. Drainage fittings shall be used on all parts of the vent below the floor level and a minimum slope of one-quarter (1/4) inch per foot (20.9 mm/m) back to the drain shall be maintained. The return bend used under the drain-board shall be a one (1) piece fitting or an assembly of a forty-five (45) degree (0.79 radius), a ninety (90) degree (1.6 radius) and a forty-five (45) degree (0.79 radius) elbow in the order named. Pipe sizing shall be as

elsewhere required in this Code. The island sink drain, upstream of the return vent, shall serve no other fixtures. An accessible cleanout shall be installed in the vertical portion of the foot vent.

62. The amendment of the Electrical Part (Chapters 34 through 43) of the International Residential Code by deleting in its entirety. The applicable code provisions are found in the Electrical Chapter of the Arlington City Code.

E. The following local amendments to the International Energy Conservation Code (I.E.C.C.) are hereby adopted:

1. The I.E.C.C. contains both commercial ("C") and residential ("R") provisions. Where an amendment cites a section number with both a C and an R number, it is understood that both sections are amended respectively.
2. The amendment of Section C101.1/R101.1, entitled **Title**, is amended to read as follows:

C101.1/R101.1 Title.

This code shall be known as the International Energy Conservation Code of the City of Arlington, Texas, and shall be cited as such. It is referred to herein as "this code".

3. The amendment of Section C102.1/R102.1, entitled **General**, by adding Section C102.1.2, entitled **Alternative compliance**, and Section R102.1.2 (N1101.4.1), entitled **Alternative compliance**, and they shall both respectively read as follows:

C102.1.2 Alternative compliance.

A building certified by a national, state, or local accredited energy efficiency program and determined by the Energy Systems Laboratory to be in compliance with the energy efficiency requirements of this section may, at the option of the Code Official, be considered in compliance. The United States Environmental Protection Agency's Energy Star Program certification of energy code equivalency shall be considered in compliance.

R102.1.2 (N1101.4.1) Alternative compliance.

A building certified by a national, state, or local accredited energy efficiency program and determined by the Energy Systems Laboratory to be in compliance with the energy efficiency requirements of this section may, at the option of the Code Official, be considered in compliance. The United States Environmental Protection Agency's Energy Star Program certification of energy code equivalency shall be considered in compliance. Regardless of the program or the path to compliance, each 1- and 2-family dwelling shall be tested for air and duct leakage as prescribed in

Section R402.4.1.2 (N1102.4.1.2) and R403.3.3 (N1103.3.3) respectively.

4. The amendment of Section C105.2/R105.2, entitled **Required Inspections**, to read as follows:

C105.2/R105.2 Required inspections.

The code official, his or her designated agent or an approved agency, upon notification, shall make the inspections set forth in Sections C105.2.1 through C105.2.6.

C105.2.1/R105.2.1 Footing and foundation inspection.

Inspections associated with footings and foundations shall verify compliance with the code as to R-value, location, thickness, depth of burial and protection of insulation as required by the code and approved plans and specifications.

C105.2.2/R105.2.2 Framing and Air Barrier rough-in inspection.

Inspections at framing and rough-in shall be made before application of interior finish insulation and shall verify compliance with the code as to: air leakage controls as required by the code; and approved plans and specifications.

C105.2.3/R105.2.3 Insulation and Fenestration rough-in inspection.

Inspections at framing and rough-in shall be made before application of interior finish and shall verify compliance with the code as to: types of insulation and corresponding R-values and their correct location and proper installation; fenestration properties such as U-factor and SHGC and proper installation.

C105.2.4/R105.2.4 Plumbing rough-in inspection.

Inspections at plumbing rough-in shall verify compliance as required by the code and approved plans and specifications as to types of insulation and corresponding R-values and protection and required controls.

C105.2.5/R105.5.5 Mechanical rough-in inspection.

Inspections at mechanical rough-in shall verify compliance as required by the code and approved plans and specifications as to installed HVAC equipment type and size, required controls, system insulation and corresponding R-value, system air leakage control, programmable thermostats, dampers, whole-house ventilation, and minimum fan efficiency.

Exception: Systems serving multiple dwelling units shall be inspected in accordance with Section C105.2.4.

C105.2.6/R105.2.6 Final inspection.

The building shall have a final inspection and shall not be occupied until approved. The final inspection shall include verification of the installation of all required building systems, equipment and controls and their proper operation and the required number of high-efficacy lamps and fixtures.

5. The amendment of Sections C104/R104, entitled **FEES**, by deleting in their entirety.
6. The amendment of Sections C109/R109, entitled **STOP WORK ORDER**, by amending the same to read as follows:

**SECTION C109/R109
STOP WORK ORDER**

C109.1/R109.1 Stop Work Order.

Whenever any work is being done contrary to the provisions of this Code, the Building Official may order the work stopped by notice in writing served on any persons engaged in the doing or causing such work to be done. Any such person shall forthwith stop such work until:

- a. He or she is authorized by the Building Official to proceed with the work; or
 - b. An appeal perfected pursuant to Section 2.06 of Article II has resulted in a waiver of the condition causing the stop order, or a finding that there is no cause for a stop order. Failure to stop such work, in addition to penalties and remedies elsewhere set forth, shall void any appeal.
7. The amendment of Section C110/R110, entitled **MEANS OF APPEALS**, by deleting in their entirety.
 8. The amendment of Section R202 (N1101.6), entitled **GENERAL DEFINITIONS**, by adding the following definitions:

DYNAMIC GLAZING. Any fenestration product that has the fully reversible ability to change its performance properties, including U-factor, solar heat gain coefficient (SHGC), or visible transmittance (VT).

PROJECTION FACTOR. The ratio of the horizontal depth of the overhang, eave or permanently attached shading device, divided by the distance measured vertically from the bottom of the fenestration glazing to the underside of the overhang, eave or permanently attached shading device.

9. The amendment of Section R401.2.5, entitled **Additional energy efficiency**, by deleting in its entirety.
10. The amendment of Table 402.1.2, entitled **MAXIMUM ASSEMBLY U-FACTORS AND FENESTRATION REQUIREMENT**, by amending the following columns and rows to read as follows.

Climate Zone	Fenestration U-Factor ^f	Ceiling U-Factor
2	0.40	0.029
3	0.32	0.029

11. The amendment of Table 402.1.3, entitled **INSULATION MINIMUM R-VALUES AND FENESTRATION REQUIREMENTS BY COMPONENT**, by amending the following columns and rows to read as follows:

Climate Zone	Fenestration U-Factor ^{b,i}	Ceiling R-Value	Wood Frame Wall R-Value	Slab R-Value & Depth
2	0.40	42	13 or 0 + 10	0
3	0.32	42	19 or 13+53ci, 0+15	10ci, 2 ft 0

12. The amendment of Section C402.5.2, entitled **Dwelling and sleeping unit enclosure testing**, to read as follows:

C402.5.2 Dwelling and sleeping unit enclosure testing.

The building thermal envelope shall be tested in accordance with ASTM E779, ANSI/RESNET/ICC 380, ASTM E1827 or an equivalent method approved by the code official. The measured air leakage shall not exceed 0.30 cfm/ft² (1.5 Us m²) of the testing unit enclosure area at a pressure differential of 0.2 inch water gauge (50 Pa). Where multiple dwelling units or sleeping units or other occupiable conditioned spaces are contained within one building thermal envelope, each unit shall be considered an individual testing unit, and the building air leakage shall be the weighted average of all testing unit results, weighted by each testing unit's enclosure area. Units shall be tested separately with an unguarded blower door test as follows:

1. Where buildings have fewer than eight testing units, each testing unit shall be tested.
2. For buildings with eight or more testing units, the greater of seven units or 20 percent of the testing units in the building shall be tested, including a top floor unit, a ground floor unit,

a middle floor unit, and a unit with the largest testing unit enclosure area. For each tested unit that exceeds the maximum air leakage rate, an additional three units shall be tested, including a mixture of testing unit types and locations.

13. The amendment of Section R402.4.1, entitled **Building thermal envelope**, by adding Section R402.4.1.4, entitled **Sampling options for R2 multifamily dwelling units**, which shall read as follows

R402.4.1.4 Sampling options for R2 multifamily dwelling units.

For buildings with eight or more testing units that must be tested as required by R402.1.2 or R402.1.3, the greater of seven units or 20 percent of the testing units in the building shall be tested, including a top floor unit, a ground floor unit, a middle floor unit, and a unit with the largest testing unit enclosure area. For each tested unit that exceeds the maximum air leakage rate, an additional three units shall be tested, including a mixture of testing unit types and locations. Where buildings have fewer than eight testing units, each testing unit shall be tested.

14. The amendment of Section R402.4.6, entitled **Electrical and communication outlet boxes (air-sealed boxes)**, to read as follows:

R402.4.6 Electrical and communication outlet boxes (air-sealed boxes).

Electrical and communication outlet boxes installed in the building thermal envelope shall be sealed to limit air leakage between conditioned and unconditioned spaces.

15. The amendment of Section R403.3, entitled **Ducts**, by adding Section R403.3.8, entitled **Sampling options for R2 multifamily dwelling units**, which shall read as follows

R403.3.8 Sampling options for R2 multifamily dwelling units.

For buildings with eight or more testing units that must be tested as required by R403.3.5, the greater of seven units or 20 percent of the testing units in the building shall be tested, including a top floor unit, a ground floor unit, a middle floor unit, and a unit with the largest testing unit floor area. For each tested unit that exceeds the maximum duct leakage rate, an additional three units shall be tested, including a mixture of testing unit types and locations. Where buildings have fewer than eight testing units, each testing unit shall be tested.

16. The amendment of Section R403.6, entitled **Mechanical Ventilation**, by adding Section R403.6.4, entitled **Sampling options for R2 multifamily dwelling units**, which shall read as follows

R403.6.4 Sampling options for R2 multifamily dwelling units.

For buildings with eight or more testing units that must be tested as required by R403.6.3, the greater of seven units or 20 percent of the testing units in the building shall be tested, including a top floor unit, a ground floor unit, a middle floor unit, and a unit with the largest testing unit floor area. For each tested unit that does not meet the minimum ventilation rate, an additional three units shall be tested, including a mixture of testing unit types and locations. Where buildings have fewer than eight testing units, each testing unit shall be tested.

17. The amendment of Section R404.2, entitled **Interior Lighting Controls**, by deleting in its entirety.
18. The amendment of Section R405.2, entitled **Performance-based compliance**, to read as follows.

R405.2 Performance-based compliance.

Compliance based on total building performance requires that a proposed design meets all of the following:

1. The requirements of the sections indicated within Table R405.2.
2. The building thermal envelope greater than or equal to levels of efficiency and solar heat gain coefficients in Table R402.1.1 or R402.1.3 of the 2009 International Energy Conservation Code.
3. An annual energy cost that is less than or equal to the annual energy cost of the 2021 standard reference design or 8% less than the annual energy cost of the 2018 standard reference design. Energy prices shall be taken from a source approved by the code official, such as the Department of Energy, Energy Information Administration's State Energy Data System Prices and Expenditures reports. Code officials shall be permitted to require time-of-use pricing in energy cost calculations.

Exception: The energy use based on source energy expressed in Btu or Btu per square foot of conditioned floor area shall be permitted to be substituted for the energy cost. The source energy multiplier for electricity shall be 3.16. The source energy multiplier for fuels other than electricity shall be 1.1.

19. The amendment of TABLE R406.5 (N1106.4), entitled **MAXIMUM ENERGY RATING INDEX**, by amending the columns and rows below to read as follows:

TABLE R406.5 (N1106.4) ¹
MAXIMUM ENERGY RATING INDEX

CLIMATE ZONE	ENERGY RATING INDEX
2	63
3	63

¹ This table is effective until August 31, 2022.

TABLE R406.5 (N1106.4) ²
MAXIMUM ENERGY RATING INDEX

CLIMATE ZONE	ENERGY RATING INDEX
2	59
3	59

² The table is effective from September 1, 2022 to August 31, 2025.

TABLE R406.5 (N1106.4) ³
MAXIMUM ENERGY RATING INDEX

CLIMATE ZONE	ENERGY RATING INDEX
2	57
3	57

³ The table is effective from September 1, 2025 to August 31, 2028.

TABLE R406.5 (N1106.4) ³
MAXIMUM ENERGY RATING INDEX

CLIMATE ZONE	ENERGY RATING INDEX
2	55
3	55

⁴ This table is effective on or after September 1, 2028.

20. The amendment of Section R408, entitled **ADDITIONAL EFFICIENCY PACKAGE OPTIONS**, by deleting in its entirety.
21. NOTE: HB 3215 was signed into law by the Governor on June 14, 2021, as part of the 87th Regular Session, and was codified in Chapter 388, Texas Building Energy Performance Standards: §388.003 (i), (j), and (k). HB 3215 now allows a Home Energy Rating System Index (ex. HERS Index) utilizing ANSI/RESNET/ICC Standard 301 (as it existed on January 1, 2021) shall be considered in compliance with State law provided that:
- The home includes compliance with the Mandatory requirements of 2018 IECC Section R406.2.

- The home includes compliance with Building thermal envelope provisions of Table R402.1.2 or Table R402.1.4 of the 2018 IECC.

F. The following local amendments to the International Existing Building Code (I.E.B.C.) are hereby adopted:

1. The amendment of Section 102.4, entitled **Referenced codes and standards.**, to read as follows:

102.4 Referenced codes and standards.

The codes, when specifically adopted, and standards referenced in this code shall be considered part of the requirements of this code to the prescribed extent of each reference and as further regulated in Sections 102.4.1 and 102.4.2.

Exception: Where enforcing a code provision would violate the conditions of the listing of the equipment or appliance, the conditions of the listing shall govern.

2. The amendment of Section 105, entitled **PERMITS**, by deleting in its entirety.
3. The amendment of Section 106, entitled **CONSTRUCTION DOCUMENTS**, by deleting in its entirety.
4. The amendment of Section 108, entitled **FEES**, by deleting in its entirety.
5. The amendment of Section 109, entitled **INSPECTIONS**, by deleting in its entirety.
6. The amendment of Section 110, entitled **CERTIFICATE OF OCCUPANCY**, by deleting in its entirety.
7. The amendment of Section 112, entitled **MEANS OF APPEALS**, by deleting in its entirety.
8. The amendment of Section 113, entitled **VIOLATIONS**, by deleting in its entirety.
9. The amendment of Section 114, entitled **STOP WORK ORDER**, by amending it in its entirety to read as follows:

**SECTION 114
STOP WORK ORDER**

114.1 Stop work orders.

Whenever any work is being done contrary to the provisions of this Code, the Building Official may order the work stopped by notice in writing served on any persons engaged in the doing or causing such work to be done. Any such person shall forthwith stop such work until:

- a. He or she is authorized by the Building Official to proceed with the work; or
- b. An appeal perfected pursuant to Section 2.05 has resulted in a waiver of the condition causing the stop order, or a finding that there is no cause for a stop order.

Failure to stop such work, in addition to penalties and remedies elsewhere set forth, shall void any appeal.

10. The amendment of Section 115, entitled **UNSAFE STRUCTURES AND EQUIPMENT**, by deleting in its entirety.
11. The amendment of Section 202, entitled **GENERAL DEFINITIONS**, by amending the definition of **EXISTING BUILDING** to read as follows:

EXISTING BUILDING. A building, structure, or space with an approved final inspection issued under a code edition which is at least 2 published code editions preceding the currently adopted building code; a building, structure or space that is undergoing a change of occupancy or use.

12. The amendment of Section 306.1, entitled **Scope.**, by adding the following Exceptions, which shall read as follows:

Exceptions:

1. Components of projects regulated by and registered with Architectural Barriers Division of Texas Department of Licensing and Regulation shall be deemed to be in compliance with the requirements of this chapter.
 2. If the cost of the project is less than \$50K, it must comply with ICC A117.1, or it shall be reviewed and inspected to the Texas Accessibility Standards by a Registered Accessibility Specialist.
13. The amendment of Section 306.2, entitled **Design.**, by adding the following Exception, which shall read as follows:

Exception: Projects subject to the Texas Accessibility Standards as adopted by the Texas Department of Licensing and Regulation are exempt

from this section. Projects with a valuation of less than \$50,000.00 (which are subject to the Texas Accessibility Standards) may be accepted as equivalent to this section where reviewed and inspected to the Texas Accessibility Standards by a Texas Department of Licensing and Regulation Registered Accessibility Specialist when a plan review report and a compliant inspection report are provided to the building code official.

14. The amendment of Section 306.5, entitled **Change of occupancy.**, by adding Section 306.5.1, entitled **Complete change of occupancy.**, which shall read as follows:

306.5.1 Complete change of occupancy.

Where an entire building undergoes a change of occupancy, it shall comply with Section 305.4.1 and shall have all of the following accessible features:

1. Not fewer than one accessible building entrance.
2. Not fewer than one accessible route from an accessible building entrance to primary function areas.
3. Signage complying with Section 1111 of the International Building Code.
4. Accessible parking, where parking is being provided.
5. Not fewer than one accessible passenger loading zone, where loading zones are provided.
6. Not fewer than one accessible route connecting accessible parking and accessible passenger loading zones to an accessible entrance.
7. At least one accessible family or assisted use toilet room shall be provided in accordance with Chapter 11 of the International Building Code.

Where it is technically infeasible to comply with the new construction standards for any of these requirements for a change of group or occupancy, Items 1 through 6 shall conform to the requirements to the maximum extent technically feasible.

Exception: The accessible features listed in Items 1 through 6 are not required for an accessible route to Type B units.

15. The amendment of Section 401.3, entitled **Flood hazard areas.**, by deleting in its entirety.

16. The amendment of Section 405.2.6, entitled **Flood hazard areas.**, by deleting in its entirety.
17. The amendment of Section 406.1, entitled **Material.**, to read as follows:

406.1 Material.
Existing electrical wiring and equipment undergoing repair shall be allowed to be repaired or replaced with like material, in accordance with the requirements of NFPA 70.
18. The amendment of Section 502.3, entitled **Flood hazard areas.**, by deleting in its entirety.
19. The amendment of Section 503.2, entitled **Flood hazard areas.**, by deleting in its entirety.
20. The amendment of Section 503.16, entitled **Enhanced classroom acoustics.**, by adding an Exception, which shall read as follows:

Exception: Compliance with the Texas Accessibility Standards is not considered equivalent compliance for the purpose of this code section.
21. The amendment of Section 504.1.2, entitled **Existing fire escapes.**, to read as follows:

504.1.2 Existing fire escapes.
Existing fire escapes shall continue to be accepted as a component in the means of egress in existing buildings only. Existing fire escapes shall be permitted to be repaired or replaced.
22. The amendment of Section 504.1.3, entitled **New fire escapes.**, by deleting in its entirety.
23. The amendment of Section 507.3, entitled **Flood hazard areas.**, by deleting in its entirety.
24. The amendment of Section 701.3, entitled **Flood hazard areas.**, by deleting in its entirety.
25. The amendment of Section 702.4, entitled **Window opening control devices on replacement windows.**, by adding a second Exception, which shall read as follows:
 2. Operable windows with openings that are provided with window fall prevention devices that comply with ASTM F2090.
26. The amendment of Section 702.7, entitled **Materials and methods.**, to read as follows:

702.7 Materials and methods.

All new work shall comply with the materials and methods requirements in the International Building Code, International Energy Conservation Code, International Mechanical Code, National Electrical Code, and International Plumbing Code, as applicable, that specify material standards, detail of installation and connection, joints, penetrations, and continuity of any element, component, or system in the building.

27. The amendment of Section 802.5.1, entitled **Minimum requirement.**, to read as follows:

802.5.1 Minimum requirement.

Every portion of open-sided walking surfaces, including mezzanines, equipment platforms, aisles, stairs, ramps, and landings that is more than 30 inches (762 mm) above the floor or grade below and is not provided with guards, or those in which the existing guards are judged to be in danger of collapsing, shall be provided with guards.

28. The amendment of Section 803.1, entitled **Scope.**, by adding a second paragraph, which shall read as follows:

For the purpose of fire sprinkler protection and fire alarm requirements included in this section, the work area shall be extended to include at least the entire tenant space or spaces bounded by walls capable of resisting the passage of smoke containing the subject work area, and if the work area includes a corridor, hallway, or other exit access, then such corridor, hallway, or other exit access shall be protected in its entirety on that particular floor level.

29. The amendment of Section 803.2.6, entitled **Supervision.**, by amending the Exception to read as follows:

Exception: Supervision is not required where the Fire Code does not require such for new construction.

30. The amendment of Section 803.3, entitled **Standpipes.**, to read as follows:

803.3 Standpipes.

Refer to Section 1103.6 of the Fire Code for retroactive standpipe requirements.

31. The amendment of Section 804.2, entitled **General.**, by deleting Exception 1 in its entirety.

32. The amendment of Section 804.4.1.2, entitled **Fire escapes required.**, to read as follows:

804.4.1.2 Fire Escapes required.

For other than Group I-2, where more than one exit is required, an existing fire escape complying with Section 805.3.1.2.1 shall be accepted as providing one of the required means of egress.

33. The amendment of Section 804.4.1.2.1, entitled **Fire escape access and details.**, to read as follows:

Section 804.4.1.2.1 Fire escape access and details.

Fire escapes shall comply with all of the following requirements:

1. Occupants shall have unobstructed access to the fire escape without having to pass through a room subject to locking.
2. Access to a fire escape shall be through a door, except that windows shall be permitted to provide access from single dwelling units or sleeping units in Group R-1, R-2 and I-1 occupancies or to provide access from spaces having a maximum occupant load of 10 in other occupancy classifications.
 - 2.1 The window shall have a minimum net clear opening of 5.7 square feet (0.53 m²) or 5 square feet (0.46 m²) where located at grade.
 - 2.2 The minimum net clear opening height shall be 24 inches (610 mm) and net clear opening width shall be 20 inches (508 mm).
 - 2.3 The bottom of the clear opening shall not be greater than 44 inches (1118 mm) above the floor.
 - 2.4 The operation of the window shall comply with the operational constraints of the International Building Code.
3. {deleted}

4. Openings within 10 feet (3048 mm) of fire escape stairways shall be protected by fire assemblies having minimum ¾-hour fire resistance ratings.

Exception: Opening protection shall not be required in buildings equipped throughout with an approved automatic sprinkler system.

5. In buildings of Group E occupancy, up to and including the 12th grade, buildings of Group I occupancy, boarding houses and childcare centers, ladders of any type are prohibited on fire escapes used as a required means of egress.

34. The amendment of Section 804.6.2, entitled **Transoms.**, to read as follows:

804.6.2 Transoms.

In all buildings of Group B, E, I-1, I-2, R-1 and R-2 occupancies, all transoms in corridor walls in work areas shall be either glazed with 1/4-inch (6.4 mm) wired glass set in metal frames or other glazing assemblies having a fire protection rating as required for the door and permanently secured in the closed position or sealed with materials consistent with the corridor construction.

35. The amendment of Section 904.1, entitled **Automatic sprinkler systems.**, to read as follows:

904.1 Automatic sprinkler systems.

An automatic sprinkler system shall be provided in a work area where required by Section 803.2 or this section.

For the purpose of fire sprinkler protection and fire alarm requirements included in this section, the work area shall be extended to include at least the entire tenant space or spaces bounded by walls containing the subject work area, and if the work area includes a corridor, hallway, or other exit access, then such corridor, hallway, or other exit access shall be protected in its entirety on that particular floor level.

36. The amendment of Section 904.1.1, entitled **High-rise buildings.**, to read as follows:

904.1.1 High-rise buildings.

An automatic sprinkler system shall be provided in work areas of high-rise building.

37. The amendment of Section 1011.2.1., entitled **Fire sprinkler system.**, to read as follows:

1011.2.1 Fire sprinkler system.

Where a change in occupancy classification occurs or where there is a change of occupancy within a space where there is a different fire protection system threshold requirement in Chapter 9 of the International Building Code that requires an automatic fire sprinkler system to be provided based on the new occupancy in accordance with Chapter 9 of the International Building Code. The installation of the automatic sprinkler system shall be required within the area of the change of occupancy and areas of the building not separated horizontally and vertically from the change of occupancy by one of the following:

1. Fire barrier, as required by Section 707 of the IBC.
2. Fire wall, as required by Section 706 of the IBC.

Exceptions:

1. An automatic sprinkler system shall not be required in a one- or two-family dwelling constructed in accordance with the International Residential Code.
2. Automatic sprinkler system shall not be required in a townhouse constructed in accordance with the International Residential Code.
3. The townhouse shall be separated from adjoining units in accordance with Section R302.2 of the International Residential Code.

38. The amendment of Section 1102.2, entitled **Area limitations.**, by adding Section 1102.2.1, entitled **Fire separations.**, which shall read as follows:

1102.2.1 Fire separations.

Where fire separations are utilized to allow additions without exceeding the allowable area provisions of Chapter 5 of the IBC for either the existing building or the new addition, the decreased clear space where the two buildings adjoin shall be accounted for in such calculation relative to the allowable frontage increase.

39. The amendment of Section 1103.3, entitled **Flood hazard areas.**, by deleting in its entirety.
40. The amendment of Section 1201.4, entitled **Flood hazard areas.**, by deleting in its entirety.

41. The amendment of Section 1301.3.2, entitled **Compliance with other codes.**, to read as follows:

1301.3.2 Compliance with other codes.

Buildings that are evaluated in accordance with this section shall comply with the International Fire Code.

42. The amendment of Section 1301.3.3, entitled **Flood hazard areas.**, by deleting in its entirety.
43. The amendment of Section 1402.6, entitled **Flood hazard areas.**, by deleting in its entirety.
44. The amendment of Section 1509, entitled **WATER SUPPLY FOR FIRE PROTECTION**, by deleting in its entirety and replacing with the following:

**SECTION 1509
WATER SUPPLY FOR FIRE PROTECTION**

1509.1 When required

An approved water supply for fire protection, either temporary or permanent, shall be made available as soon as combustible material arrives on the site. The water supply design and the timing of the water supply installation relative to building construction shall comply with the adopted Fire Code.

- G. The following local amendments to the International Swimming Pool and Spa Code (I.S.P.S.C.) are hereby adopted:
1. The deletion of Section 101.1, entitled **Title**.
 2. The deletion of Section 101.3, entitled **Purpose**.
 3. The amendment of Section 102.9, entitled **Other laws**, to read as follows:

Section 102.9 Other laws.

The provisions of this code shall not be deemed to nullify any provisions of local, state or federal law, including but not limited to the following:

1. Texas Department of State Health Services (TDSHS); Standards for Public Pools and Spas; §285.181 through §285.208, (TDSHS rules do not apply to pools serving one- and two-family dwellings or townhouses).
2. Texas Department of Licensing and Regulation (TDLR); 2012 Texas Accessibility Standards (TAS), TAS provide the scoping and technical requirements for accessibility for Swimming Pool, wading

pools and spas and shall comply with 2012 TAS, Section 242. (TAS rules do not apply to pools serving one- and two-family dwellings or townhouses).

Exception: Elements regulated under Texas Department of Licensing and Regulation (TDLR) and built-in accordance with TDLR approved plans, including any variances or waivers granted by the TDLR, shall be deemed to comply with the requirements of this Chapter.

4. The amendment of Section 103.1, entitled **Creation of enforcement agency**, to read as follows:

Section 103.1 Creation of enforcement agency.

The City of Arlington Building Inspections Department is hereby created and the official in charge thereof shall be known as the Building Official. The City of Arlington Code Compliance Services Department is hereby created and the official in charge thereof shall be known as the Code Official for operation and maintenance of any public swimming pool in accordance with this code, local and state law.

5. The amendment of Section 104.6, entitled **Right of entry**, to read as follows:

104.6 Right of entry.

Whenever necessary to make an inspection to enforce any of the provisions of this Code, or whenever the Administrative Authority or their authorized representative has reasonable cause to believe that there exists in any building or upon any premises any condition or code violation which makes such building or premises unsafe, dangerous or hazardous, the Administrative Authority or their authorized representative may enter such building or premises at all reasonable times to inspect the same or to perform any duty imposed upon the Administrative Authority by this Code. If such building or premises be unoccupied, they shall first make a reasonable effort to locate the owner or other persons having charge or control of the building or premises and request entry. If such entry is refused, or if no owner or other person having charge or control of the building or premises can be located, the Administrative Authority or their authorized representative shall obtain a warrant pursuant to the "Municipal Court" Chapter of the Code of the City of Arlington.

6. The amendment of Section 105.4, entitled **Permit issuance**, to read as follows:

105.4 Permit issuance.

The application, plans, specifications, computations, and other data filed by an applicant for permit shall be reviewed by the Administrative Authority. Such plans may be reviewed by other departments of this jurisdiction to verify compliance with applicable laws under their jurisdiction. If the

Administrative Authority finds that the work described in an application for a permit and the plans, specifications and other data filed therewith conform to the requirements of this Code and other pertinent laws and ordinances and that the fees specified in Section 105.6 have been paid, they shall issue a permit therefore to the applicant. "Applicant" in this usage shall conform to the provisions of Sections 4.01 of the Construction Chapter of the Arlington City Code.

7. The amendment of Section 105.6, entitled **Fees and refunds**, to read as follows:

105.6 Fees and refunds.

Any person, firm or corporation desiring a permit as required by this Building Code shall, at or before the time of permit issuance, pay a fee as specified in the fee structure as approved by the City Council of the City of Arlington by resolution and which may be amended from time to time by said City Council.

8. The amendment of Section 106.1, entitled **Construction documents**, by adding the following paragraph:

Design, construction, or renovation of Class A and Class B pools and spas, therapeutic pools and spas, surf pools, wave pools, and pools with a movable bottom, drop slide, or waterslide constructed on or after the effective date of this amendment shall be planned and designed by a licensed engineer.

9. The amendment of Section 107.3, entitled **Prosecution of violation**, by deleting it in its entirety.

10. The amendment of Section 110.13, entitled **Testing**, to read as follows:

110.13 Testing.

Pool and Spa systems shall be tested as required in this code and in accordance with Sections 110.14 through 110.16. Tests shall be made by the permit holder and may be observed by the Building Official, his designee, or the Code Compliance Services Department.

11. The amendment of Section 111, entitled **MEANS OF APPEAL**, by deleting in its entirety.

12. The amendment of Section 112, entitled **BOARD OF APPEALS**, by amending in its entirety to read as follows:

**SECTION 112
BOARD OF APPEALS**

112.1 Board of Appeals.

The Building Code Board of Appeals shall act as a Board of Appeals as provided in Article II of this Chapter.

13. The amendment of Section 113.4, entitled **Violation penalties**, to read as follows:

113.4 Violation Penalties.

It shall be unlawful for any person, firm or corporation to erect, construct, enlarge, alter, repair, move, improve, remove, convert or demolish, equip, use or maintain any mechanical systems or equipment or cause or permit the same to be done in violation of this Code.

A person convicted of violating any of the provisions of this Code shall be guilty of a misdemeanor and each day or portion thereof during which any such violation continues shall be a separate offense. Each offense shall be punishable by a fine of not more than \$2,000.00.

The issuing or granting of a permit or approval of plans and specifications by the City shall not be deemed or construed to be a permit for, or an approval of, any violation of any of the provisions of this Code or any other ordinance of the City. No permit presuming to give authority to violate or cancel the provisions of this Code, or any other ordinance of the City, shall be valid, except insofar as the work or use which is authorized is lawful.

The issuing or granting of a permit or approval of plans by the City shall not prevent the Administrative Authority from thereafter requiring the correction of errors in said plans and specifications or from preventing construction operations being carried on thereunder when in violation of this Code or of any other ordinance of the City, or from revoking any certificate of approval when issued in error.

14. The amendment of Section 114, entitled **STOP WORK ORDER**, by amending it in its entirety to read as follows:

**SECTION 114
STOP WORK ORDER**

114.1 Stop work orders.

Whenever any work is being done contrary to the provisions of this Code, the Building Official may order the work stopped by notice in writing served on any persons engaged in the doing or causing such work to be done. Any such person shall forthwith stop such work until:

- a. He or she is authorized by the Building Official to proceed with the work; or
- b. An appeal perfected pursuant to Section 2.05 has resulted in a waiver of the condition causing the stop order, or a finding that there is no cause for a stop order.

Failure to stop such work, in addition to penalties and remedies elsewhere set forth, shall void any appeal.

15. The amendment of Section 202, entitled **DEFINITIONS**, by adding the definitions of "Building Code", "Existing Pool or Spa System", "Code Compliance Services Department", and "Shall", and amending the definition of "Code Official":

BUILDING CODE. The "Construction" Chapter of the Code of the City of Arlington, 1987, as amended.

CODE OFFICIAL. The officer or other designated authority charged with the administration and enforcement of this code, or a duly authorized representative. The Code Official is also the Building Official and Administrative Authority.

CODE COMPLIANCE SERVICES DEPARTMENT. The team regulating the operation of public pools. Routine inspections on pools and spas open to the public are conducted to document compliance with the standards set forth in State law.

EXISTING POOL or SPA SYSTEM. Any system, apparatus or equipment that has been approved for operation within the City by the Administrative Authority prior to the adoption of this Code.

SHALL. As it applies to an act or duty to be performed by the Administrative Authority pursuant to any section of this Code, is discretionary. Its use in all other applications in this Code shall be mandatory.

16. The amendment of Section 305.1, entitled **General.**, to read as follows:

Section 305.1 General.

The provisions of this section shall apply to the design of barriers for restricting entry into areas having pools and spas. In only one- and two-family dwellings and townhouses, where spas or hot tubs are equipped with a lockable safety cover complying with ASTM F1346 and swimming pools are equipped with a powered safety cover that complies with ASTM F1346, the areas where those spas, hot tubs or pools are located shall not be required to comply with Sections 305.2 through 305.7.

17. The amendment of Section 305.2.7., entitled **Chain link dimensions**, by adding Section 305.2.7.1, entitled **Chain link fencing prohibited**, which shall read as follows:

305.2.7.1 Chain link fencing prohibited.

Chain link fencing is not permitted as a barrier in public pools built after January 1, 1994.

18. The amendment of Section 305.4, entitled **Structure wall as a barrier**, by amending the first paragraph to read as follows:

305.4 Structure wall as a barrier.

Where a wall of a dwelling or structure of a one- and two-family dwelling or townhouse or its accessory structure serves as part of a barrier and where doors or windows provide direct access to the pool or spa through that wall, one of the following shall be required:

19. The amendment of Section 305.6, entitled **Natural barriers**, to read as follows:

305.6 Natural barriers used in a one- and two-family dwelling or townhouse.

In the case where the pool or spa area abuts the edge of a lake or other natural body of water, public access is not permitted or allowed along the shoreline, and required barriers extend to and beyond the water's edge a minimum of eighteen (18) inches, a barrier is not required between the natural body of water shoreline and the pool or spa.

20. The amendment of Section 307.1.4., entitled **Accessibility**, by adding an Exception, which shall read as follows:

Exception: Components of projects regulated by and registered with Architectural Barriers Division of Texas Department of Licensing and Regulation shall be deemed to comply with the requirements of this chapter.

21. The amendment of Section 307.2.2, entitled **Materials and structural design**., by adding Section 307.2.2.2, entitled **Adjacency to Structural Foundation**, which shall read as follows:

Section 307.2.2.2. Adjacency to Structural Foundation.

Depth of the swimming pool and spa shall maintain a ratio of 1:1 from the nearest building foundation or footing of a retaining wall.

Exception: A sealed engineered design drawing of the proposed new structure shall be submitted for approval.

22. The amendment of Section 310.1, entitled **General**, to read as follows:

310.1 General.

Suction entrapment avoidance for pools and spas shall be provided in accordance with APSP 7 (ANSI/PHITA/ICC 7) or for public swimming pools in accordance with State of Texas Rules for Public Swimming Pools and Spas, Title 25 TAC Chapter 265 Subchapter L, Rule §265.190.

Exceptions:

1. Portable spas and portable exercise spas listed and labeled in accordance with UL 1563 or CSA C22.2 No. 218.1
2. Suction entrapment avoidance for wading pools shall be provided in accordance with Section 405.

23. The amendment of Section 402.12, entitled **Water envelopes**, by amending in its entirety to read as follows:

402.12. Water envelopes.

The minimum diving water envelopes shall be in accordance with Table 402.12 Texas Department of State Health Services, Administrative Code Title 25, Chapter 265, Section 186 (e) and Figure: 25 TAC 256.186 (e) (6).

Table 402.12 Texas Department of State Health Services, Administrative Code Title 25, Chapter 265, Section 186 (e)

Maximum Diving Board Height Over Water	¼ Meter	1 Meter	3 Meters
Max. Diving Board Length	12 ft.	16 ft.	16 ft.
Minimum Diving Board Overhang	2 ft. 6 in.	5 ft.	5 ft.
D1 Minimum	8 ft. 6 in.	11 ft. 2 in.	12 ft. 2 in.
D2 Minimum	9 ft.	10 ft. 10 in.	11 ft. 10 in.
D3 Minimum	4 ft.	6 ft.	6 ft.
L1 Minimum	4 ft.	5 ft.	5 ft.
L2 Minimum	12 ft.	16 ft. 5 in.	19 ft. 9 in.
L3 Minimum	14 ft. 10 in.	13 ft. 2 in.	13 ft. 11 in.
L4 Minimum	30 ft. 10 in.	34 ft. 7 in.	38 ft. 8 in.
L5 Minimum	8 ft.	10 ft.	13 ft.
H Minimum	16 ft.	16 ft.	16 ft.
From Plummet to Pool Wall at Side	9 ft.	10 ft.	11 ft. 6 in.
From Plummet to Adjacent Plummet	10 ft.	10 ft.	10 ft.

Figure: 25 TAC 256.186 (e) (6)

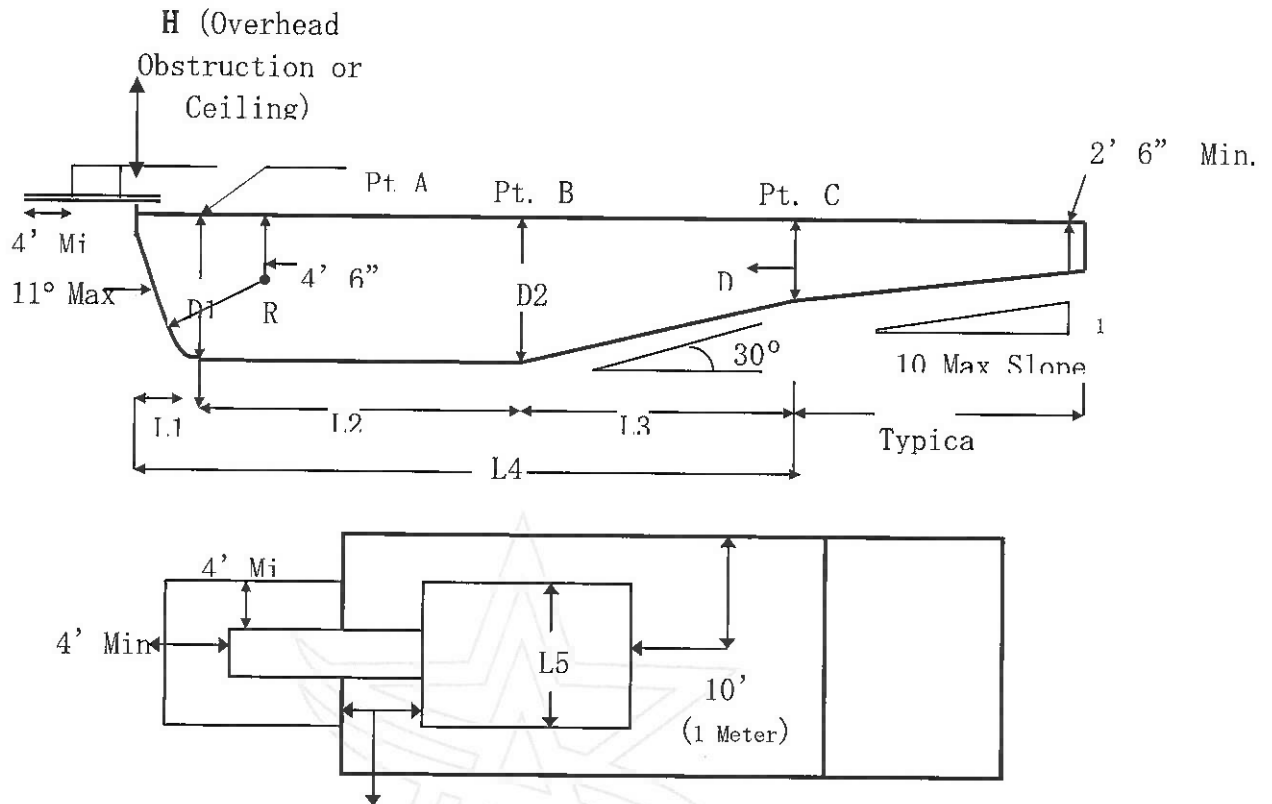

24. The amendment of Section 411.2, entitled **Pool stairs**, by amending Section 411.2.1 and Section 411.2.2 to read as follows:

411.2.1 Tread dimensions and area.

Treads shall have a minimum unobstructed horizontal depth (i.e., horizontal run) of 12 inches and a minimum width of 20 inches, not be less than 24 inches (607mm) at the leading edge. Treads shall have an unobstructed surface area of not less than 240 square inches (154838mm²) and an unobstructed horizontal depth of not less than 10 inches (254 mm) at the center line.

411.2.2 Risers.

Risers for steps shall have a maximum uniform height of 10 inches, with the bottom riser height allowed to taper to zero except for the bottom riser, shall have a uniform height of not greater than 12 inches (305 mm) measured at the center line. The bottom riser height is allowed to vary to the floor.

25. The amendment of Section 411.5.1, entitled **Swimouts**, to read as follows:

411.5.1 Swimouts.

Swimouts, located in either the deep or shallow area of a pool, shall comply with all of the following:

1. The horizontal surface shall be no greater than 20 inches (508 mm) below the waterline.
2. An unobstructed surface shall be provided that is equal to or greater than that required for the top tread of the pool stairs in accordance with Section 411.2.
3. Where used as an entry and exit access, swimouts shall be provided with steps that comply with the pool stair requirements of Section 411.2.
4. The leading edge shall be visibly set apart and provided with a horizontal solid or broken stripe at least 1 inch wide on the top surface along the front leading edge of each step. This stripe shall be plainly visible to persons on the pool deck. The stripe shall be a contrasting color to the background on which it is applied, and the color shall be permanent in nature and shall be a slip-resistant surface.

26. The amendment of Section 411.5.2, entitled **Underwater seats and benches**, by amending Item 5 to read as follows:

5. The leading edge shall be visually set apart and provided with a horizontal solid or broken stripe at least 1 inch wide on the top surface along the front leading edge of each step. This stripe shall be plainly visible to persons on the pool deck. The stripe shall be a contrasting color to the background on which it is applied, and the color shall be permanent in nature and shall be a slip-resistant surface.

27. The amendment of Section 610.5.1., entitled **Uniform height of 9 inches.**, shall be retitled and amended to read as follows:

610.5.1 Uniform height of 10 inches.

Except for the bottom riser, risers at the centerline shall have a maximum uniform height of 10 inches (254 mm). The bottom riser height shall be permitted to vary from the other risers.

28. The amendment of Section 804.1, entitled **General.**, to read as follows:

Section 804.1 General.

The minimum diving water envelopes shall be in accordance with Table 804.1 and Figure 804.1, or the manufacturer's specifications, whichever is

greater. Negative construction tolerances shall not be applied to the dimensions of the minimum diving water envelopes given in Table 804.1.

Section 1.05 Adoption of Appendices

The following referenced provisions of the I.B.C., I.R.C. and I.E.C.C. annexed hereto as appendices, the same being either attached hereto or incorporated herein by reference, are made a part of this Building Code.

Appendix A. Only Appendix C, entitled GROUP U-AGRICULTURAL BUILDINGS of the Appendix to the International Building Code, 2009 Edition.

All other Chapters of said Appendix to the I.B.C. are hereby omitted from this Building Code.

Appendix B. Only Appendix G, entitled SWIMMING POOLS, SPAS AND HOT TUBS, as amended, of the Appendix to the International Residential Code, 2009 Edition.

All other Chapters of said Appendix to the I.R.C. are hereby omitted from this Building Code.

Further, that **Article IV, Registration, Permits and Inspections**, is hereby repealed and replaced in its entirety and shall hereafter read as follows:

ARTICLE IV

REGISTRATION, PERMITS AND INSPECTIONS

Section 4.01 Registration

- A. **Registration Required.** It shall be unlawful for any person, firm or corporation to erect, construct, enlarge, alter, repair, move, improve, remove, convert or demolish any building, sign or structure in the City of Arlington, or cause the same to be done, unless such person, firm or corporation is the holder of a valid registration with said City to perform such work. Such person, firm or corporation shall be herein termed Registrant. In extending the rights and privileges of such registration, said City makes no statement of the technical competency of those so registered, and no manner of license is proffered.
- B. An applicant for registration under this article shall provide to the Building Official, or his authorized representative, the following information:
1. The complete name, complete mailing address and telephone number of the firm or corporation;

2. The name and private mailing address of a principal of the firm or corporation who is a person authorized to bind the firm or corporation in legal agreements;
3. If the registration is to be as an individual only, the name, mailing address and telephone number of the individual; and
4. Other pertinent information deemed necessary by the Building Official.

Every Registrant shall contact the office of the Building Official to ensure the accurate revision of registration information, including any change of address or telephone number.

Every Registrant doing work in any City rights-of-way shall, at their own expense, carry Commercial General Liability Insurance with a combined single limit of not less than One Million Dollars (\$1,000,000) per occurrence, with an aggregate of not less than Two Million Dollars (\$2,000,000). The Registrant shall make the City of Arlington a Certificate Holder and present proof of insurance at the time of registration and all subsequent renewals. Notice of policy cancellations or failure to renew coverage shall be cause for revocation of registration, denial of inspections or cancellation of permits.

Notice of policy cancellations or failure to renew coverage shall be cause for revocation of registration, denial of inspections or cancellation of permits.

- C. **Building Official Shall Respond.** After application for registration has been received, the Building Official, or his authorized representative, shall act promptly to issue the registration or to determine upon what basis the registration may not be issued. The Building Official shall respond to the applicant not later than ten (10) business days following receipt of the application.
- D. **Expiration and Renewal of Registration.** A registration may be renewed at any time without a penalty. A registration requires submittal of registration information and payment of fee as outlined in the fee resolution adopted by city council.
- E. **Transfer of Registration.** No Registrant under this article shall for any purpose allow the registration, by name or other identification, to be transferred or assigned to, or in any manner directly or indirectly used by, any person, firm or corporation other than the one to whom the registration was issued, unless a Company representative other than the registered principal provides a statement from the principal in order to transact business.
- F. **Homeowner Registration.** A homeowner's registration shall be required for work to be performed on an existing structure when the person performing the work is the owner of the structure who resides therein as his homestead. The homeowner shall be termed a Registrant for the purposes of such a project after proper

registration. All requirements for permits for the work and all other applicable provisions of this Building Code shall remain in force.

Section 4.02 Commercial Site Plan and Permits Required

A. It shall be unlawful for any Registrant or person without first obtaining a separate building permit for such work from the Building Official:

1. to erect, construct, enlarge, alter, repair, move, improve, remove, convert or demolish any building or structure;

EXEMPTION: see exemptions in Subsections (B) and (C) below.

2. to install, enlarge or repair any fence;

EXEMPTION: Repair or replacement of fencing where not less than 50% of one side of the fence is being repaired and/or replaced; not applicable to pool barrier fencing

3. to erect, alter a sign, including the copy face or lettering of any sign, either by changing the message or by renovating an existing message, or erect any sign or sign structure;

EXEMPTION: Changing a changeable copy message or a message center sign message; general maintenance such as repainting the same message or changing the face of a sign permitted as an off-site advertising sign;

4. to reroof any building or structure;

5. to excavate, grade, or fill property, or cause the same to be done;

EXEMPTION: Excavation for construction of a structure permitted under this code; Refuse disposal sites controlled by other regulations; Excavations for wells, or trenches for utilities; Mining, quarrying, excavating, processing or stockpiling rock, sand, gravel, aggregate or clay controlled by other regulations, provided such operations do not affect the lateral support of, or significantly increase stresses in, soil on adjoining properties; or, Exploratory excavations performed under the direction of a registered design professional.

Separate permits are required for electrical, plumbing and mechanical work as set forth in the Electrical, Mechanical and Plumbing Chapters of this Code.

B. Permits shall not be required for the following items. Exemption from permit requirements of this code shall not be deemed to grant authorization for any work to be done in any manner in violation of the provisions of this code or any other laws or ordinances.

1. Retaining walls that are not over 4 feet (1219 mm) in developed height at any point when measured from the bottom of the footing to the top of the wall, unless supporting a surcharge or imposed load or impounding Class I, II or IIIA liquids. See Article 1 of this Chapter regarding "tiered" retaining walls.
 2. Painting, papering, tiling, carpeting, cabinets, counter tops and similar finish work.
 3. Swings and other playground equipment.
 4. Prefabricated inflatable swimming pools that are less than 24 inches (610 mm) deep.
 5. Window awnings supported by an exterior wall which do not project more than 54 inches (1372 mm) from the exterior wall and do not require additional support.
 6. Replacement of siding materials with materials of similar character. The installation of siding systems such as, but not necessarily limited to, stucco and Exterior Insulation and Finish Systems, require a permit.
 7. Nonfixed and movable fixtures, cases, racks, counters and partitions not over 5 feet 9 inches (1753 mm) in height.
 8. Shade cloth structures constructed for nursery or agricultural purposes.
- C. For 1-and 2-family structures only regulated by the I.R.C., permits shall not be required for the following items. Exemption from permit requirements of this code shall not be deemed to grant authorization for any work to be done in any manner in violation of the provisions of this code or any other laws or ordinances.
1. Building:
 - a. One-story detached accessory structures used as tool and storage sheds and similar uses, provided the floor area does not exceed 100 square feet (9.29 m²).
 - b. Flatwork (pedestrian sidewalks, vehicle parking and maneuvering areas) on private property.
 2. Electrical:
 - a. Listed cord-and-plug connected temporary decorative lighting.
 - b. Reinstallation of attachment plug receptacles but not the outlets thereof.

- c. Replacement of branch circuit over current devices of the required capacity in the same location.
- d. Electrical wiring, devices, appliances, apparatus or equipment operating as less than 25 volts and not capable of supplying more than 50 watts of energy.
- e. Minor repair work, including the replacement of lamps or the connection of approved portable electrical equipment to approved permanently installed receptacles.

3. Plumbing

- a. Portable heating, cooking or clothes drying appliances.
- b. Replacement of any minor part that does not alter approval of equipment or make such equipment unsafe.
- c. Portable-fuel-cell appliances that are not connected to a fixed piping system and are not interconnected to a power grid.
- d. The stopping of leaks in drains, water, soil, waste or vent pipe; provided, however, that if any concealed trap, drainpipe, water, soil, waste or vent pipe becomes defective and it becomes necessary to remove and replace the same with new material, such work shall be considered as new work and a permit shall be obtained and inspection made as provided in this code.
- e. The clearing of stoppages or the repairing of leaks in pipes, valves or fixtures, and the removal and reinstallation of water closets, provided such repairs do not involve or require the replacement or rearrangement of valves, pipes or fixtures.

4. Mechanical

- a. Portable heating appliances.
- b. Portable ventilation appliances.
- c. Portable cooling units.
- d. Steam, hot- or chilled-water piping within any heating or cooling equipment regulated by this code.
- e. Replacement of any minor part that does not alter approval of equipment or make such equipment unsafe.

- f. Portable evaporative coolers.
 - g. Self-contained refrigeration systems containing 10 pounds (4.54 kg) or less of refrigerant or that are actuated by motors of 1 horsepower (746 W) or less.
 - h. Portable-fuel-cell appliances that are not connected to a fixed piping system and are not interconnected to a power grid.
- D. **Emergency Repairs.** Where equipment replacements and repairs must be performed in an emergency situation, the permit application shall be submitted within the next working day to the building official.
- E. For other than 1 and 2 family dwellings, approval of a Commercial Site Plan is required prior to filing the application for a building permit. Two copies of the "Accepted for Construction" Commercial Site Plan shall be submitted with each application for a building permit for the following work categories:
- 1. The construction of a new building,
 - 2. The construction of an addition to an existing building.
 - 3. The grading, excavation or filling of a parcel when such work is not included in the scope of an issued building permit.
- F. A Commercial Site Plan shall demonstrate compliance with the applicable zoning, environmental, fire and engineering regulations specific to the proposed project.
- G. A permit shall be issued only to a Registrant meeting the conditions of Section 4.01 above, and only after all other requirements defined in this article have been accomplished.
- H. Work Performed without Required Permits.
- 1. This subsection applies to a person who owns, occupies, or exercises control over a building or premises where work described by Subsection (A) is performed that requires a building permit, electrical permit, mechanical permit, or plumbing permit.
 - 2. A person who performs work described by Subsection (A) or who allows such work to be performed at a building or premises has a duty to obtain all required permits from the Building Official prior to such work being performed. If work described by Subsection (A) is performed without first obtaining a required permit from the Building Official, a person has a continuing duty to obtain any required permit for the work that was performed.

3. When work described by Subsection (A) is performed at a building or premises without first obtaining any required permit from the Building Official, it shall be unlawful for a person to own, occupy, keep, maintain, or exercise control over the building or premises until any required permit is obtained for the work that was performed. Each day that the person owns, occupies, keeps, maintains, or exercises control over the building or premises where such work was performed without having obtained any required permit shall constitute a separate offense.

Section 4.02.5 Application for Commercial Site Plan

- A. To obtain approval for a Commercial Site Plan, the applicant shall first file an application with the Building Official, or his authorized representative, on a form furnished for that purpose by said Building Official. Every such application shall:
 1. Identify and describe the proposed development;
 2. Describe the land on which the proposed work is to be done by lot, block, tract and building and street address, or similar description that will readily identify and definitely locate the proposed building or work;
 3. Be accompanied by plans and specifications as required to demonstrate compliance with the zoning, environmental, engineering and fire regulations applicable to the project location;
 4. Be signed by the applicant or an authorized agent, who may be required to submit evidence to indicate such authority; and
 5. Give such other pertinent information as is deemed necessary by the Building Official.
- B. Accepted plans and specifications shall not be changed, modified or altered without written authorization from the Building Official, and all work shall be done in accordance with the approved plans.
- C. Final plans or other documents that will be archived must be submitted in an electronic format specified by the Director of Planning and Development Services ("PDS Director") as a condition to issuance of any type of permit, approval, or other action related to the final plans or documents. The City may provide an electronic conversion service for a fee in the amount set forth by City Council resolution. The PDS Director shall provide a schedule indicating which documents must be provided electronically, at which point during the approval process, and other information as necessary to implement an electronic archiving program.

Section 4.03 Application for Permit

To obtain a permit, the applicant shall first file an application with the Building Official, or his authorized representative, on a form furnished for that purpose by said Building Official. Every such application shall:

- A. Identify and describe the work to be covered by the permit for which application is made;
- B. Describe the land on which the proposed work is to be done, by lot, block, tract, and building and street address, or similar description that will readily identify and definitely locate the proposed building or work;
- C. Indicate the use or occupancy for which the proposed work is intended;
- D. Be accompanied by plans and specifications as required in Section 4.04 of this article below;
- E. State the fair market construction valuation of the proposed work;
- F. Be signed by the applicant (Registrant) or an authorized agent, who may be required to submit evidence to indicate such authority;
- G. Give such other pertinent information as is deemed necessary by the Building Official.

Section 4.04 Plans and Specifications

- A. With each application for a building permit and when required by the Building Official for enforcement of any provisions of this Building Code, plans and specifications shall be submitted. The Building Official may require plans, computations and specifications to be prepared and designed by an engineer or architect licensed by the State of Texas to practice as such even if not required by State law. The engineers' or architects' professional seal shall be affixed to the documents.

EXCEPTION: The Building Official, or an authorized representative, may waive the submission of plans, calculations, construction, inspection requirements and other data if it is found that the nature of the work applied for is such that reviewing of plans is not necessary to obtain compliance with the Code.

- B. Plans and specifications shall be drawn to scale and shall be of sufficient clarity to indicate the nature and extent of the work proposed and show in detail that it will conform to the provisions of this Building Code and all other relevant laws, ordinances, rules and regulations. The first sheet of each set of plans shall give the building and street address where the work is to be performed and the name and address of the owner and person who prepared said plans. Plans shall include a plot

plan showing the location of the proposed building and of every existing building on the property. In lieu of detailed specifications, the Building Official may approve references on the plans to a specific section or part of this Building Code or other ordinances or laws. The construction documents shall also be in conformance with the following:

- (1) **Means of egress.** The construction documents shall show in sufficient detail the location, construction, size and character of all portions of the means of egress in compliance with the provisions of this code. In other than occupancies in Groups R-2, R-3, and I-1, the construction documents shall designate the number of occupants to be accommodated on every floor, and in all rooms and spaces.
- (2) **Exterior wall envelope.** Construction documents for all buildings shall describe the exterior wall envelope in sufficient detail to determine compliance with this code. The construction documents shall provide details of the exterior wall envelope as required, including flashing, intersections with dissimilar materials, corners, end details, control joints, intersections at roof, eaves or parapets, means of drainage, water-resistive membrane and details around openings.

The construction documents shall include manufacturer's installation instructions that provide supporting documentation that the proposed penetration and opening details described in the construction documents maintain the weather resistance of the exterior wall envelope. The supporting documentation shall fully describe the exterior wall system which was tested, where applicable, as well as the test procedure used.

- (3) **Demolition permits.** In the case of proposed demolition, the site plan shall show construction to be demolished and the location and size of existing structures and construction that are to remain on the site or plot.
- C. Computations, stress diagrams and other data sufficient to show the correctness of the plans shall be submitted when required by the Building Official. Plans by the applicant for buildings more than two (2) stories in height of other than Group R-3 and U Occupancies shall indicate how required structural and fire-restrictive integrity will be maintained where a penetration will be made for electrical, mechanical, plumbing and communications conduits and pipes, and similar systems.
- D. Final plans or other documents that will be archived must be submitted in an electronic format specified by the Director of Planning and Development Services ("PDS Director") as a condition to issuance of any type of permit, approval, or other action related to the final plans or documents. The City may provide an electronic conversion service for a fee in the amount set forth by City Council resolution. The PDS Director shall provide a schedule indicating which documents must be provided electronically, at which point during the approval process, and other information as necessary to implement an electronic archiving program.

Section 4.05 Building Permits Issued

- A. The Building Official shall examine or cause to be examined the application, plans and specifications filed by an applicant for a permit shall be reviewed. Such plans may also be reviewed by other departments of the City of Arlington to check compliance with the laws and ordinances under their jurisdiction, including but not limited to review by the Water Utilities, Fire, Code Compliance Services, Planning and Development Services, and the Public Works Department of the City of Arlington to ensure compliance with the Traffic Study Provisions adopted by resolution of the City Council. If the Building Official finds that the work described in an application for permit and the plans filed therewith conform to the requirements of this Building Code and other pertinent laws and that the permit fees have been paid, a permit shall be issued.

EXCEPTION: Except by specific approval by the Building Official, or an authorized representative, a permit shall not be issued in a development where the construction of streets, drainage, water, sewer and other such public improvement facilities have not been completed and accepted by the City of Arlington.

In lieu of the plan review performed by the Building Official, the owner of a property may choose to contract with a Third Party Provider that is properly registered with the City for plan review. Plan reviews performed by Third Party Organizations are subject to the terms of the program as authorized by resolution of the City Council of the City of Arlington.

- B. **Approval of construction documents.** When the building official issues a permit, the construction documents shall be approved, in writing or by stamp, as:

"CITY OF ARLINGTON APPROVED PLANS. These plans must be kept on the job site and be available at the inspector's request. Changes to these plans must be approved in the same manner as these plans were approved."

One set of construction documents so reviewed shall be retained by the building official. The other set shall be returned to the applicant, shall be kept at the site of work and shall be open to inspection by the building official or a duly authorized representative.

- C. Accepted plans and specifications shall not be changed, modified or altered without written authorization from the Building Official, and all work shall be done in accordance with the plans.
- D. The Building Official may issue a permit for the construction of part of a building or structure before the entire plans and specifications for the whole building or structure have been submitted or approved, provided adequate information and detailed statements have been filed complying with all pertinent requirements of

this Building Code. The holder of such permit shall proceed at personal risk without assurance that the permit for the entire building or structure will be granted.

Deferred submittals.

For the purposes of this section, deferred submittals are defined as those portions of the design that are not submitted to the building official at the time of the application and that are to be submitted to the building official within a specified period.

Deferred submittals shall have the prior approval of the building official. The registered design professional in responsible charge shall list the deferred submittals on the construction documents for review by the building official.

Documents for deferred submittal items shall be submitted to the registered design professional in responsible charge who shall review them and forward them to the building official with a notation indicating that the deferred submittal documents have been reviewed and found to be in general conformance to the design of the building. The deferred submittal items shall not be installed until the deferred submittal documents have been approved by the building official.

- E. The issued Building Permit shall contain the address and legal description of the location, the name of the general contractor and a description of the work. The Building Permit shall be posted on the job location at all times during the time the building permit is valid and may not be removed until such time that the Building Official issues a final approval. The Building Permit shall be posted in front of the building so that it is visible from the addressed street or fire lane at all times. Work may be ordered to stop when such Building Permit is not displayed in accordance with this section.

Section 4.05.5 Expiration of Commercial Site Plan

Every Commercial Site Plan approved by the Building Official under the provisions of this Building Code shall expire by limitation of time and become null and void if the owner, agent or authorized developer has not filed a valid application for a building permit within one hundred eighty (180) days from the date of approval of the Commercial Site Plan. An expired Commercial Site Plan must be reviewed as a new application before an application for a building permit may be submitted.

Section 4.06 Validity of Permit

The issuance or granting of a permit or acceptance of plans and specifications shall not be construed to be a permit for, or an approval of, any violation of any of the provisions of this Building Code or any other applicable law. No permit presuming to give authority to violate or cancel the provisions of this Building Code shall be valid, except as the work or use, which it authorizes, is lawful.

The issuance of a permit based upon plans and specifications shall not prevent the Building Official from thereafter requiring the correction of errors in said plans and specifications or from preventing building operations being carried on thereunder when in violation of this Building Code or of any other chapter of the Code of the City of Arlington.

In the event a court of competent jurisdiction determines that lawfully filed deed restrictions or lawfully filed real property restrictive covenants on single family residential property within the City of Arlington would be violated by the construction that is the subject of the permit, such court may restrain or enjoin the Building Official from issuing the building permit for a period not to exceed sixty (60) days.

Section 4.07 Expiration of Permit

Every permit issued by the Building Official under the provisions of this Building Code shall expire by limitation of time and become null and void if the building or work authorized by such permit is not commenced within one hundred eighty (180) days from the date of such permit, or if the building or work authorized by such permit is suspended or abandoned for a period of one hundred eighty (180) days at any time after the work is commenced.

Any permittee holding an expired permit may apply in writing for an extension of the time within which work may commence under that permit when the permittee is unable to commence work within the time required for good and satisfactory reasons. The Building Official may extend the time for action by the permittee for a period not exceeding one hundred eighty (180) days. The permittee shall pay a fee for the extension of an expired permit. No permit shall be extended more than once.

Section 4.08 Suspension or Revocation of Permit

The Building Official may, in writing, suspend or revoke a permit issued under provisions of this Building Code whenever the permit is issued in error or on the basis of incorrect information having been supplied, or in violation of any law, including any provision of the Code of the City of Arlington. The Building Official may also deny building inspections or new permits to a contractor whose business registration with the City of Arlington is not in active status.

Section 4.09 Building Permit Fees

A fee for each permit required by this Building Code and any plan review fees shall be set by resolution of the City Council and shall be paid to the Building Official prior to the issuance of such permit and review of any plans. The determination of value or valuation hereunder shall be made by said Building Official. The valuation-based permit and plan review fees shall be the total value of all construction work for which the permit is issued, as well as all finish work, painting, roofing, electrical, plumbing, heating, air conditioning, elevators, fire-extinguishing systems and any other permanent work or

permanent equipment. Calculations for area (square footage) shall be on a gross basis, measured from the exterior face of exterior walls. "Valuation" shall be the estimate of the total market value of a proposed construction project, including the contractor's overhead and profit and other associated owner's costs, but excluding raw land costs. All permit fees including other non-valuation-based permit fees are outlined in the fee resolution adopted by city council.

Where work for which a permit is required by this Building Code is begun prior to obtaining said permit, the specified fees shall include an investigation fee of the site in addition to the permit fee such fees shall not exempt the applicant from compliance with all other provisions of either this code or the technical codes nor from penalty prescribed by law.

Section 4.10 Plan Review Fees

When issuance of a permit depends on review and acceptance of drawings depicting the proposed work, a plan review fee shall be paid at the time of submitting the drawings for review. The plan review fee shall be non-refundable. The building permit application shall not be received until the plan review fee is paid. The plan review fee shall be set from time to time by resolution of the City Council of the City of Arlington.

Section 4.11 Expiration of Building Permit Application and Plan Review

An application for which no building permit is issued within one hundred eighty (180) days following the date of application may be voided due to limitation of time, and plans submitted for review may thereafter be returned to the applicant or destroyed by the Building Official. The Building Official may extend the time for action on the application due to circumstances beyond the control of the applicant which have prevented action from being taken. The application may be extended for an additional 180 days upon a request in writing submitted to the Building Official. The application may be extended upon approval by the Building Official and payment of the extension fee prior to the expiration of the building permit application. An expired application may only be reactivated by the filing of a new application, including plans and fees. An applicant's written request for voluntary withdrawal of the application shall be deemed to be the same as an expiration of the application.

Section 4.11.5 Expiration of Commercial Site Plan Application

An application for a Commercial Site Plan that is not approved for permitting within one hundred eighty (180) days following the date of application may be voided due to limitation of time, and plans submitted for review may thereafter be returned to the applicant or destroyed by the Building Official. The Building Official may extend the time for action on the application due to circumstances beyond the control of the applicant which have prevented action from being taken. The application may be extended for an additional 180 days upon a request in writing submitted to the Building Official. The application may

be extended upon approval by the Building Official. An expired application may only be reactivated by the filing of a new application, including plans and any fees prior to the expiration of the Commercial Site Plan. An applicant's written request for voluntary withdrawal of the application shall be deemed to be the same as an expiration of the application.

Section 4.12 Refunds

A plan review fee is non-refundable. The Building Official, or an authorized representative, may approve the refund of a permit fee. Any permit fee refund shall be reduced by any applicable service charge. When the permit has been issued through an error on the part of the City of Arlington, and it is found that the work applied for cannot be allowed, the refund should be made in full. Any applicable service charges shall not exceed the total permit fee. The Building Official, or an authorized representative, may refuse to consider a request for refund received more than 90 days after payment of the permit fee.

Section 4.13 Inspections

- A. **General.** All construction or work for which a permit is required shall be subject to inspection by the Building Official, or an authorized representative, and certain types of construction may have continuous inspection by special inspectors as specified in Section 4.14 below.

A survey of the lot may be required by the Building Official to verify compliance of the structure with approved plans. It shall be the duty of the permittee to cause the work to be accessible and exposed for inspection purposes.

EXCEPTION: The owner of a property may choose to contract with a Third Party Provider that is properly registered with the City for inspections. Inspections performed by Third Party Organizations are subject to the terms of the program as authorized by resolution of the City Council of the City of Arlington. A Third Party Provider shall not be authorized to grant final approval or grant a Certificate of Occupancy.

- B. **Approvals Required.** No work shall be done on any part of the building or structure beyond the point indicated in each successive inspection without the permittee first obtaining the written approval of the Building Official. Such written approval shall be given only after an inspection has been made of each successive step in the construction as indicated by each of the Required Inspections. Failure by the permittee to contact the Building Official for any required inspection shall be an offense.

There shall be a final inspection and approval on all buildings when completed and ready for occupancy before such occupancy is allowed to occur.

- C. **Required Inspections.** It shall be the duty of the holder of the building permit or their duly authorized agent to notify the building official when work is ready for inspection. It shall be the duty of the permit holder to provide access to and means for inspections of such work that are required by this code.

Work shall not be done beyond the point indicated in each successive inspection without first obtaining the approval of the building official. The building official, upon notification, shall make the requested inspections and shall either indicate the portion of the construction that is satisfactory as completed, or notify the permit holder or his or her agent wherein the same fails to comply with this code. Any portions that do not comply shall be corrected and such portion shall not be covered or concealed until authorized by the building official.

The Building Official, upon notification from the permit holder or an authorized agent, shall make the following inspections and shall either approve that portion of the construction as completed or shall notify the permit holder or an authorized agent in what respects the same fails to comply with this Building Code:

1. Footing and foundation inspections. Footing and foundation inspections shall be made after excavations for footings are complete and any required reinforcing steel is in place. For concrete foundations, any required forms shall be in place prior to inspection. Materials for the foundation shall be on the job, except where concrete is ready mixed in accordance with ASTM C 94, the concrete need not be on the job.
2. Concrete slab and under-floor inspection. Concrete slab and under-floor inspections shall be made after in-slab or under-floor reinforcing steel and building service equipment, conduit, piping accessories and other ancillary equipment items are in place, but before any concrete is placed or floor sheathing installed, including any subflooring.
3. Lowest floor elevation. In flood hazard areas, upon placement of the lowest floor, including the basement, and prior to further vertical construction, the elevation certification required in Section 1612.5 shall be submitted to the building official.
4. Frame inspection. Framing inspections shall be made after the roof deck or sheathing, all framing, fire-blocking and bracing are in place and pipes, chimneys and vents to be concealed are complete and the rough electrical, plumbing, heating wires, pipes and ducts are approved. As applicable, residential building seconds would include mechanical rough, electrical rough, plumbing top-out and framing.
5. Lath and gypsum board inspection. Lath and gypsum board inspections shall be made after lathing and gypsum board, interior and exterior, is in place, but before any plastering is applied or gypsum board joints and fasteners are taped and finished.

EXCEPTION: Gypsum board that is not part of a fire-resistance-rated assembly or a shear assembly.

6. Fire-resistant penetrations. Protection of joints and penetrations in fire-resistance-rated assemblies shall not be concealed from view until inspected and approved.
 7. Energy efficiency inspections. Inspections shall be made to determine compliance with the energy code and shall include, but not be limited to, inspections for:
 - a. envelope air leakage and insulation installation and R and U values;
 - b. fenestration U values and SHGC values,
 - c. duct system sealing and insulation R values;
 - d. HVAC and water-heating equipment efficiency, and
 - e. Lighting switching and wattage allowances.
 8. Other inspections. In addition to the inspections specified above, the building official is authorized to make or require other inspections of any construction work to ascertain compliance with the provisions of this code and other laws that are enforced by the department of building safety.
 9. Special inspections. For special inspections, see Section 1704 of the IBC.
 10. Final inspection. The final inspection shall be made after all work required by the building permit is completed.
- D. **Other Inspections.** In addition to the required inspections specified in Subsection (C) above, the Building Official may make or require any other inspections of any construction work to ascertain compliance with the provisions of this Building Code and other applicable laws which are enforced by the City of Arlington.

For the purpose of determining compliance with I.B.C., Section 3402 the Building Official may cause any structure to be reinspected.

E. **Reinspections.**

A fee as established by city council resolution may be charged when:

1. The inspection called for is not ready when the inspector arrives;
2. No building address or permit card is clearly posted;
3. City approved plans are not on the job site available to the inspector;

4. The building is locked or work otherwise not available for inspection when called;
5. The job site is red-tagged twice for the same item;
6. The original red tag has been removed from the job site; or
7. Failure to maintain erosion control, trash control or tree protection.

Any re-inspection fees assessed shall be paid before any more inspections are made on that job site.

Section 4.14 Certificate of Occupancy

- A. When required. No premises, building or structure shall be used or occupied until a Certificate of Occupancy has been issued as provided herein. A certificate of occupancy is required when:
 1. The initial occupancy of a building or tenant space.
 2. To change the tenancy or tenant of building or tenant space.
 3. To change the name or ownership of a business.
 4. A shell Certificate of Occupancy shall not permit the occupancy of the structure for any purposes. A shell Certificate of Occupancy is for purposes of utility releases for house meters.
 5. A "clean and show" certificate of occupancy shall not permit the occupancy of the structure, with the exception of cleaning and preparing the building or tenant space for showing prospective tenants.
- B. Reserved.
- C. Certificate Issued. The Building Official shall issue a Certificate of Occupancy upon a finding that the premises complies with the Building Code, provisions of the "Unified Development Code" Chapter of the Code and all other applicable development regulations of the City of Arlington. For new structures or when the occupant is of a different character of occupancy or use from the previous certificate holder, the Building Official shall make an inspection. Where no change in character of occupancy is proposed for a structure previously granted a Certificate of Occupancy, no inspection is necessary unless specifically required by the Building Official. In the event that a tenant space is being altered, enlarged or reduced in size, or if the Building Official, or an authorized representative, believes that the previous tenant altered the space without benefit of permits, an inspection may be required prior to the occupancy. Other City departments may require inspections prior to the granting of a Certificate of Occupancy. Issuance of a

Certificate of Occupancy shall not be construed as an approval of a violation of the provisions of this code or of other ordinances of the jurisdiction.

An applicant for a Sexually Oriented Business as required by the Sexually Oriented Business Chapter of the City Code must first obtain a Certificate of Occupancy for a Sexually Oriented Business from the Building Official. The Building Official shall issue or deny a Certificate of Occupancy to a Sexually Oriented Business not more than sixty (60) business days subsequent to the date of the applicant's submission of such application to the Building Official. Such application for a Certificate of Occupancy shall be deemed approved if not approved or denied within such time period.

The Certificate of Occupancy shall contain:

1. The address of the building;
2. The name of the business located at said premises, building or structure;
3. The allowable zoning use and occupancy for which the certificate is issued;
4. The zoning district in which the use is located;
5. A description of that portion of the structure for which the certificate is issued;
6. A statement that the described portion of the structure has been inspected for compliance with the requirements of this code;
7. The name of the building official;
8. The edition of the code under which the certificate was issued;
9. The type of construction as defined in Chapter 6 of the International Building Code;
10. The design occupant load;
11. Where an automatic sprinkler system is provided, whether the sprinkler system is required; and
12. Any special conditions of the granting of the certificate.

- D. Temporary Certificate of Occupancy. A temporary Certificate of Occupancy may be issued by the Building Official for the use of a portion or portions of a building, structure, or site prior to the completion of the entire building, structure or site improvements but only if that portion or portions can be occupied safely. The Building Official shall set a time period during which the temporary Certificate of Occupancy is valid.

- E. Posting. The Certificate of Occupancy shall be posted in a conspicuous place on the premises and shall not be removed without permission of the Building Official.
- F. Revocation. The Building Official may, in writing, suspend or revoke a Certificate of Occupancy or a temporary Certificate of Occupancy issued under the provisions of this Code whenever the certificate is issued in error, or on the basis of incorrect information supplied, or when it is determined that the building or structure or portion thereof is in violation of any ordinance or regulation or any provision of this Code or other provisions of law. Upon suspension or revocation of a Certificate of Occupancy, the Building Official shall have the authority to disconnect, or to order the electricity supply agency to disconnect, all electric service to any premises affected by the revoked or suspended Certificate of Occupancy.
- G. Permits, Inspections, Certificates and Approvals for Sexually Oriented Businesses. The provisions of Subsections 4.01 (H), (I) and (J) of the Sexually Oriented Business Chapter of the Code of the City of Arlington, Texas, 1987, apply and prevail over any provision of this Construction Chapter with respect to the processing of applications, permits, inspections, certificates and approvals regarding sexually oriented businesses.
- H. Application Required. Any person, firm or corporation desiring to initially occupy a building or tenant space, to change the tenancy of building or tenant space, change the name or ownership of a business, to clean and show a building or tenant space or to acquire a Certificate of Occupancy for a shell building must complete an application and submit to the Building Official for review along with the application fee as set forth by resolution by the City Council. The application shall contain the following information:
1. The address of the application,
 2. The proposed business name of the occupant and/or tenant,
 3. The proposed use of the building or tenant space,
 4. The gross floor area of the proposed use,
 5. The individual's name of the principal or owner of the proposed use of the building or lease space, or the name of a presiding officer of a firm, corporation, partnership or other business entity of the proposed use of the building or lease space,
 6. The mailing address (other than location being applied for) of the principal or owner,
 7. The Texas Driver's License number or other government issued picture identification of the principal or owner,

8. Proof of Texas Sales and Use Tax Certificate or Tax-Exempt Certificate with a valid City of Arlington business locations for proposed businesses that will collect a sales and/or use tax, and
9. Other information as determined necessary for the building official to determine that the proposed use satisfies all the development regulations of the City of Arlington.

The application shall be submitted and signed by the principal, owner or designated agent of the principal or owner and the designated agent's Texas Driver's License number or other government issued picture identification certifying that the applicant is authorized agent so empowered to make the application on behalf of the principal or owner and agrees to be subject to the same rules of review and approval as the principal or owner.

Section 4.14.5 Mobile Food Establishment Certificate of Occupancy

- A. It shall be unlawful for a person or entity to own or operate a mobile food establishment on private property within the City of Arlington without a valid mobile food establishment certificate of occupancy ("MFE-CO") tied to an appropriate certificate of occupancy in an approved underlying land use, or as part of a preapproved temporary outdoor event (under Section 13.12, herein). A mobile food establishment is commonly referred to as a "food truck" and shall be capable of immediate mobility by use of a licensed motor vehicle. This definition shall include the term "mobile food unit" under state law, including the Texas Food Establishment Rules, or its successor statute.
- B. The holder of a valid certificate of occupancy granted under Section 4.14 above may apply for a MFE-CO to be tied to the underlying certificate of occupancy if the existing underlying certificate of occupancy is for one of the following nonresidential uses:
 1. Restaurant;
 2. Bar;
 3. Microbrewery, microdistillery, and winery; and
 4. Theatre.
- C. A MFE-CO may only be approved for a property located in a Downtown Business (DB) zoning use district or within a non-residential or mixed-use zoning use district located in the Downtown Neighborhood Overlay (DNO). Said zoning use districts are defined in the "Unified Development Code" Chapter of the Arlington City Code.

- D. An MFE-CO shall only remain valid as long as the corresponding underlying certificate of occupancy. If the underlying certificate of occupancy expires, ceases to operate, or is revoked for any reason, the validity of the MFE-CO shall also automatically terminate without notice or any further action of the City.
- E. An MFE-CO may only be approved for operation on properties that have sufficient restroom facilities for their customers within the underlying property use, together with the additional customers of the mobile food establishment.
- F. It shall be unlawful for any mobile food establishment to operate, park, stand, or remain on any public street, alley, or right-of-way unless part of a preapproved event sponsored by the City of Arlington.
- G. It shall be unlawful for any mobile food establishment to operate without a current, valid health permit issued by the City of Arlington.
- H. The underlying property owner (holder of a MFE-CO) shall be responsible for ensuring that any mobile food establishment that operates on the property has a valid motor vehicle operator license, valid vehicle registration, proof of vehicle liability insurance, and a validly issued Texas Sales Tax Permit.
- I. The underlying property owner (holder of a MFE-CO) shall be responsible for maintaining a log on a form prescribed by the Planning and Development Services Department. It shall be unlawful for the holder of a MFE-CO to fail to record and maintain on said log the name and contact information of every mobile food establishment that has operated on the premises of the underlying property owner during the past and the corresponding dates of their operation. It shall be unlawful for the holder of a MFE-CO, or his representative, to fail to provide access to said logs upon request by a representative of the City of Arlington.
- J. It shall be unlawful for a mobile food establishment to operate if the underlying certificate of occupancy holder is closed. If for any reason the underlying business must close its doors, all mobile food establishment operations must cease immediately.
- K. It shall be unlawful for a mobile food establishment to remain on the premises of a MFE-CO holder for longer than 24 consecutive hours.
- L. It shall be unlawful for a mobile food establishment to operate an electric generator on the premises of a MFE-CO holder. An approved electric line must be provided by the MFE-CO holder for use by a mobile food establishment.

Section 4.15 Indemnification

REGISTRANTS UNDER THIS BUILDING CODE SHALL INDEMNIFY, WAIVE ALL CLAIMS, RELEASE, DEFEND AND HOLD HARMLESS THE CITY OF ARLINGTON AND ALL OF ITS OFFICIALS, OFFICERS, AGENTS,

EMPLOYEES AND INVITEES, IN BOTH THEIR PUBLIC AND PRIVATE CAPACITIES, FROM ANY AND ALL LIABILITY, CLAIMS, SUITS, DEMANDS OR CAUSES OF ACTION, INCLUDING ALL EXPENSES OF LITIGATION AND/OR SETTLEMENT WHICH ARISE FROM OR RESULT FROM THE ISSUANCE AND EXERCISE OF A PERMIT ISSUED HEREUNDER PURSUANT TO AN APPLICATION FROM A REGISTRANT, WHETHER SUCH CLAIMS AND/OR DAMAGES ARISE BY REASON OF INJURY OR DEATH OF ANY PERSON, OR FOR LOSS OF, DAMAGE TO OR LOSS OF USE OF ANY PROPERTY. SUCH INDEMNITY WILL APPLY WHETHER THE CLAIMS, SUITS, LOSSES, DAMAGES, CAUSES OF ACTION OR LIABILITY ARISE IN PART FROM THE NEGLIGENCE OF THE CITY OF ARLINGTON OR ANY OF ITS OFFICERS, OFFICIALS, AGENTS, EMPLOYEES AND INVITEES IN BOTH THEIR PUBLIC AND PRIVATE CAPACITIES WHETHER SUCH NEGLIGENCE IS CONTRACTUAL COMPARATIVE NEGLIGENCE, CONCURRENT NEGLIGENCE, JOINT NEGLIGENCE, GROSS NEGLIGENCE, ACTIVE NEGLIGENCE, PASSIVE NEGLIGENCE OR ANY OTHER FORM OF NEGLIGENCE.

Section 4.16 Historical Review of Permits for Demolition or Relocation

Upon receiving an application for a permit to demolish or relocate a building or structure from a person or entity other than a state, city, county or federal government fee simple owner, the Building Official, or an authorized representative, shall determine whether the building or structure is fifty (50) years old or older, or is situated in a Landmark Preservation Overlay ("LP") Zoning District. If the building or structure is fifty (50) years old or older, or the age of the building cannot be ascertained, the Building Official, or an authorized representative, shall notify the applicant of such fact, and follow the procedures set out in Subsection A, below.

If the building or structure is situated in a "LP" Overlay District the Building Official shall notify the applicant of such fact, and follow the procedures set out in Subsection B, below. If the building or structure is less than fifty (50) years old and is not zoned with a "LP" Overlay suffix, the Building Official shall issue a demolition permit if all other requirements of the Code are met.

A. Buildings or Structures that are Fifty (50) Years Old or Older, and Buildings or Structures of Unknown Age

If the building or structure is fifty (50) years old or older, or the age of the building cannot be ascertained, the Building Official shall inform the applicant that the Landmark Preservation Commission or City Council must authorize the Building Official, or an authorized representative, to issue a permit to demolish or relocate said building or structure, or the Municipal Court must issue an order before the Building Official may issue the requested permit. The Building Official shall forward the application for a permit to demolish or relocate a building to the Landmark Preservation Commission for its review and consideration.

EXCEPTION 1: Compliance with this section is not required upon receipt of an application for demolition or relocation for a structure that has been previously reviewed by the Landmark Preservation Commission in accordance with this chapter.

EXCEPTION 2: Compliance with this section is not required if the Building Official, or an authorized representative, finds that the building or structure at issue was completely destroyed or substantially damaged by fire. For the purposes of this section, "substantially damaged" shall mean having its value reduced by more than fifty per cent (50%).

1. Automatic Stay of Forty-five (45) Days. Demolition or relocation of the building or structure shall be automatically stayed for a period of up to forty-five (45) days from the date of application to allow the Landmark Preservation Commission an opportunity to determine whether the building or structure is historically significant.
 - a. If the building or structure is determined to be historically significant the Landmark Preservation Commission shall provide proper notice and hold a public hearing on the permit application.
 - b. If the building or structure is determined not to be historically significant the Landmark Preservation Commission shall so notify the applicant and the Building Official as soon as is reasonably practicable.
2. Public Hearing. Within forty-five (45) days of the receipt of a completed application for a permit to demolish or relocate a historic building or structure, the Landmark Preservation Commission shall hold a public hearing. Public notice of such hearing setting forth the date, time and place scheduled for such hearing and the purpose thereof shall be published in a newspaper one time at least seven (7) days prior to the date scheduled for such hearing.
3. Authorization Deemed to issue a Demolition or Relocation Permit by Lack of Action. If the Landmark Preservation Commission takes no action within forty-five (45) days of receipt of the completed application, authorization to issue a permit to demolish or relocate a building or structure shall be deemed approved by the Landmark Preservation Commission.
4. Review. In evaluating a request for authorization to issue a permit to demolish or relocate a building or structure, the Landmark Preservation Commission shall consider the following:
 - a. the architectural, cultural, or historical significance of the building or structure;
 - b. the age of the building or structure;

- c. the state of repair of the building or structure in question, and the reasonableness of the cost of restoration and repair;
 - d. additions, alterations, changes, modifications and updates to the exterior architectural features of the building or structure that would disqualify it from consideration for registration on the National Register of Historic Places;
 - e. the impact, if any, that delaying the demolition or relocation of the building or structure will have;
 - f. the contribution, if any, the building or structure makes to a previously designated and recognized historic district and the owner's or any predecessor owner's involvement in the formation or creation of such a district;
 - g. the willingness of the applicant to donate or sell the building or structure to a third party;
 - h. the potential usefulness or adaptive reuse of the building or structure, including economic usefulness;
 - i. the potential market or demand for such a building or structure in its current condition and location;
 - j. the purpose that would be served in preserving the building or structure; and,
 - k. all other factors it finds necessary and appropriate to carry out the intent of this ordinance.
5. Demolition or Relocation Appropriate. If the Landmark Preservation Commission determines that the building or structure should be demolished or removed, the Building Official, or an authorized representative, shall issue a demolition permit if all other requirements of the Code are met.
6. Demolition or Relocation Inappropriate. If the Landmark Preservation Commission determines that the building or structure should not be demolished, the Landmark Preservation Commission may extend the automatic stay for a period of up to forty-five (45) additional days. The automatic stay and any additional stay imposed by the Landmark Preservation Commission shall not exceed a total of ninety (90) days from the date application for a permit to demolish or relocate a building or structure was filed.
7. Stay Extended by City Council. Prior to the expiration of the stay period imposed by the Landmark Preservation Commission, the Landmark

Preservation Commission may issue a recommendation to the City Council requesting that the stay be extended. After notice to the applicant and a public hearing, the City Council may extend the stay upon a finding that there are reasonable grounds for preservation as well as a reasonable expectation of preserving the building or structure. It shall be the responsibility of the Landmark Preservation Commission and any other proponent of extending the stay on a demolition permit application to demonstrate to the City Council's satisfaction that there exist reasonable grounds for preservation as well as a reasonable expectation of preserving the building or structure.

The City Council may extend the stay on one or more occasions, after notice to the applicant and a public hearing, in such increments of time as the City Council may determine reasonable. Any extension of the stay on a demolition permit or combination of extensions imposed by the City Council under this provision shall not exceed a cumulative total of ninety (90) days in duration.

In instances where the City Council imposes an extension of the stay for a time period of less than ninety (90) days, the Landmark Preservation Commission may request additional extensions of the stay up to a cumulative total of ninety (90) days from the City Council. Any such request must be submitted to, and acted upon by, the City Council prior to the expiration of any stay period previously imposed by the City Council. The Landmark Preservation Commission shall report to City Council concerning its efforts to preserve the building or structure as a prerequisite to the extension of any stay imposed by the City Council.

In no event shall the stay on a demolition permit and any extensions thereto exceed a total of one hundred fifty (150) days from the date the application for a permit to demolish or relocate a building or structure was filed. If City Council takes no action on the Landmark Preservation Commission's request for an extension within the original stay period or any subsequent extension thereof, authorization to issue a permit to demolish or relocate a building or structure shall be deemed approved at the expiration of such stay period.

8. Appeals. Appeals from a decision of the Landmark Preservation Commission shall be to the City Council. Such appeals must be filed with the Historic Preservation Officer within ten (10) days after the complained of decision is made by the Landmark Commission. Such appeals shall be heard by City Council on the next available agenda consistent with the requirements of the Texas Open Meetings Act and with due consideration for the City Council's schedule of business.
9. Permit Issuance. At the end of the stay period and any extension thereof, or upon the City Council's granting an appeal to the Landmark Preservation

Commission's determination the Building Official shall issue a demolition permit if all other requirements of the Code are met.

B. Buildings or Structures in a Landmark Preservation Overlay ("LP") Zoning District

If the building or structure is situated in a "LP" Overlay District the Building Official shall inform the applicant that the Landmark Preservation Commission or City Council must authorize the Building Official, or an authorized representative, to issue a permit to demolish or relocate said building or structure, or the Municipal Court must issue an order before the Building Official may issue the requested permit. The Building Official shall forward the application for a permit to demolish or relocate a building to the Landmark Preservation Commission for its review and consideration.

The Landmark Preservation Commission or City Council must authorize a permit to demolish or relocate a building, or the Municipal Court must issue an order, before the Building Official, or an authorized representative, may issue a permit to demolish or relocate a building or structure situated in a "LP" Overlay District. The permit review process, which must be followed, is set out in Section 10.4.10 of the Unified Development Code Chapter of the Code of the City of Arlington, Texas. In addition to obtaining authorization to issue a permit to demolish or relocate a building or structure from the Landmark Preservation Commission or City Council, the applicant must meet all other requirements of the Code before the Building Official shall issue a demolition permit.

C. Buildings or Structures that are NOT Located in a Landmark Preservation Overlay ("LP") Zoning District and which are Less Than Fifty (50) Years Old

If the age of a building or structure can be ascertained and the building is less than fifty (50) years old and the building or structure is not zoned with a "LP" Overlay district, the Building Official shall issue a demolition permit if all other requirements of the Code are met.

Further, Article V, Required Fees, is hereby repealed and replaced in its entirety and shall hereafter read as follows:

ARTICLE V

RESERVED

Further, Article VII, Signs, Section 7.10, Temporary Signs Near Polling Places, Subsection (A), is hereby amended so that said Subsection shall be and read as follows:

- A. Temporary signs near polling places shall comply with Elections Chapter §4.04, as amended.

2.

Any person, firm, corporation, agent or employee thereof who violates any of the provisions of this ordinance shall be guilty of a misdemeanor and upon conviction thereof shall be fined an amount not to exceed Two Thousand Dollars and No Cents (\$2,000.00) for each offense. Each day that a violation is permitted to exist shall constitute a separate offense.

3.

This ordinance shall be and is hereby declared to be cumulative of all other ordinances of the City of Arlington; and this ordinance shall not operate to repeal or affect any of such other ordinances except insofar as the provisions thereof might be inconsistent or in conflict with the provisions of this ordinance, in which event such conflicting provisions, if any, in such other ordinance or ordinances are hereby repealed.

4.

If any section, subsection, sentence, clause or phrase of this ordinance is for any reason held to be unconstitutional, such holding shall not affect the validity of the remaining portions of this ordinance.

5.

All of the regulations provided in this ordinance are hereby declared to be governmental and for the health, safety and welfare of the general public. Any member of the City Council or any City official or employee charged with the enforcement of this ordinance, acting for the City of Arlington in the discharge of his/her duties, shall not thereby render himself/herself personally liable; and he/she is hereby relieved from all personal liability for any damage that might accrue to persons or property as a result of any act required or permitted in the discharge of his/her said duties.

6.

Any violation of this ordinance can be enjoined by a suit filed in the name of the City of Arlington in a court of competent jurisdiction, and this remedy shall be in addition to any penal provision in this ordinance or in the Code of the City of Arlington.

7.

The caption and penalty clause of this ordinance shall be published in a newspaper of general circulation in the City of Arlington, Texas, in compliance with the provisions of Article VII, Section 15, of the City Charter. Further, this ordinance may be published in pamphlet form and shall be admissible in such form in any court, as provided by law.

8.

This ordinance shall become effective January 1, 2023.

PRESENTED AND GIVEN FIRST READING on the 25th day of October, 2022, at a regular meeting of the City Council of the City of Arlington, Texas; and GIVEN SECOND READING, passed and approved on the 1st day of November, 2022, by a vote of 8 ayes and 0 nays at a regular meeting of the City Council of the City of Arlington, Texas.

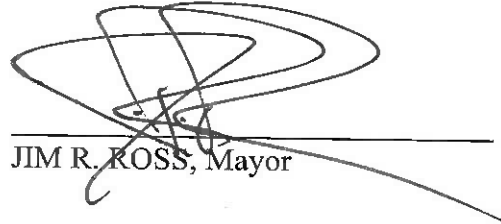

JIM R. ROSS, Mayor

ATTEST:



ALEX BUSKEN, City Secretary

APPROVED AS TO FORM:
MOLLY SHORTALL, City Attorney

BY 